

INSTALLATION | OWNER'S MANUAL



VITA | Fireplaces

LUCIJA | Suspended Gas Fireplace

MODEL

PMG-1290-LUCIJA

SERIAL NO.

YYMMDD-VLCO2XX-XXXXXX



Fireplace has been tested and certified to meet the standards of: ANSI Z21.50:19 - CSA 2.22:19 Vented Decorative Gas Appliances Certified under : ICC-ES PMG-1290

INSTALLER: Leave this manual with the appliance.
CONSUMER: Retain this manual for future reference.

WARNING:

FIRE OR EXPLOSION HAZARD

Failure to follow safety exactly could result in serious injury, death, or property damage.

- Do not store or use gasoline or other flammable vapors and liquids in the vicinity of this or any other appliance.
- **WHAT TO DO IF YOU SMELL GAS**
- Do not try to light any appliance.
- Do not touch any electrical switch; do not use any phone in your building.
- Leave the building immediately.
- Immediately call your gas supplier from a neighbor's phone. Follow the gas supplier's instructions
- If you cannot reach your gas supplier, call the fire department.
- Installation and service must be performed by a qualified installer, service agency or the gas supplier.

This appliance may be installed in an aftermarket, permanently located, manufactured home (USA only) or mobile home, where not prohibited by local codes.

This appliance is only for use with the type of gas indicated on the rating plate. This appliance is not convertible for use with other gases.

The installation must conform with local codes or, in the absence of local codes, to the National Fuel Gas Code, ANSI 2223.1/NFPA 54, or the Natural Gas and Propane Installation Code, CSA B149.1.

FOR USE WITH GLASS DOORS CERTIFIED WITH THE APPLIANCE ONLY

IMPORTANT: Read this owner's manual thoroughly before trying to assemble, operate, or service this Fireplace. Improper use of this unit can cause serious injury or death from burns, fire, explosion, electrical shock, and carbon monoxide poisoning.

WARNING: Improper installation, adjustment, alteration, service, or maintenance can cause injury or property damage. Refer to the owner's information manual provided with this.

FIREPLACE SAFETY INSTRUCTIONS

VENTED DECORATIVE GAS APPLIANCE: NOT A SOURCE OF HEAT; NOT FOR USE WITH SOLID FUEL.

CAUTION: HOT WHILE IN OPERATION. DO NOT TOUCH. SEVERE BURNS MAY RESULT. KEEP CHILDREN, CLOTHING, FURNITURE, GASOLINE AND OTHER LIQUIDS HAVING FLAMMABLE VAPORS AWAY. APPLIANCE. FOR ASSISTANCE OR ADDITIONAL INFORMATION, CONSULT A QUALIFIED INSTALLER, SERVICE AGENCY, OR THE GAS SUPPLIER.

WARNING: PROVISIONS FOR ADEQUATE COMBUSTION AND VENTILATION AIR MUST BE PROVIDED.

WARNING: THE APPLIANCE MUST NOT BE CONNECTED TO A CHIMNEY FLUE SERVING A SEPARATE SOLID-FUEL BURNING APPLIANCE.

WARNING: PROVISIONS FOR ADEQUATE COMBUSTION AND VENTILATION AIR MUST BE PROVIDED.

DANGER: Carbon monoxide poisoning may lead to death! Carbon Monoxide Poisoning: Early signs of carbon monoxide poisoning resemble the flu, with headaches, dizziness, or nausea. If you have these signs, the fireplace may not be working properly. Get fresh air at once! Have fireplace serviced. Some people are more affected by carbon monoxide than others. These include pregnant women, people with heart or lung disease or anemia, those under the influence of alcohol, and those at high altitudes.

WARNING: KEEP FLUE OPEN WHEN OPERATING UNIT.

WARNING: ANY CHANGE TO THIS FIREPLACE OR ITS CONTROLS CAN BE DANGEROUS.

Due to high temperatures, the appliance should be located out of traffic and away from furniture and draperies.

Children and adults should be alerted to the hazards of high surface temperature and should stay away to avoid burns or clothing ignition.

Young children should be carefully supervised when they are in the same room as the appliance. Toddlers, young children, and others may be susceptible to accidental contact burns. A physical barrier is recommended if there are at-risk individuals in the house. To restrict access to a fireplace or stove, install an adjustable safety gate to keep toddlers, young children, and other at-risk individuals out of the room and away from hot surfaces.

Do not use this appliance if any part has been under water. Immediately call a qualified service technician to inspect the appliance and to replace any part of the control which has been under water.

Installation and repair should be done by a qualified service person. The appliance should be inspected before use and at least annually by a professional service person. More frequent cleaning may be required due to excessive lint from carpeting, bedding material, etcetera. It is imperative that control compartments, burners, and circulating air passageways of the appliance be kept clean.

This gas appliance and its main gas valve must be disconnected from the gas-supply system during any pressure testing of that system at test pressures in excess of 1/2 psig. The appliance must be isolated from the gas supply piping system by closing the equipment shut-off valve during any pressure testing of the gas supply piping system at test pressures equal to or less than 1/2 psi (3.5 kpa).

Keep burner and control; compartment clean. See installation and operating instructions accompanying appliance.

For use only with automatic vent damper Part No. 201.0000.1206. Follow installation instructions.

Venting terminals shall not be recessed into a wall or siding.

In Canada, also certified for installation in a bedroom or bed sitting room.

FIREPLACE SAFETY INSTRUCTIONS

Any safety screen, guard, or barrier removed for servicing an appliance must be replaced prior to operating the appliance.

Clothing or other flammable material should not be placed on or near the appliance.

When the appliance is installed directly on carpeting, tile, or other combustible material other than wood flooring, the appliance shall be installed on a metal or wood panel extending the full width and depth of the appliance.

Damper must be in open position when appliance main burner(s) is operating.

Do not remove the rating plates or the warning tags. These are an integral safety and identification component of this appliance.

Gas may be present even though no odor exists. Make certain you read and understand all warnings. Keep this manual for reference. It is your guide to safe and proper operation of this fireplace.

Fireplace is designed to be smokeless. If it ever appears to smoke, turn off appliance and call a qualified service person. However, during initial operation, slight smoking could occur due to unit curing and the burning of manufacturing residues.

Do not allow fans to blow directly into the fireplace. Avoid any drafts that alter burner flame patterns, as it could increase sooting

Do not burn solid fuel in the fireplace after installing the fireplace. Do not use this appliance to cook food or burn paper or other objects.

Insufficient Gas pressure will keep the pilot (if equipped) from operating properly. Do not use if Gas pressure is lower than the minimum requirement.

Input ratings shown in BTU per hour are for elevations up to 2,000 ft., refer to the National Fuel Gas Code or contact manufacturer before installing this product.

Contact local building or fire officials about restrictions and installation inspection requirements in your area. The authority having jurisdiction should be consulted before installation to determine the need to obtain a permit (*such as Municipal Building Department, Fire Department, Fire Prevention Bureau, etc.*).

Only high heat Silicone must be used to seal each connection points and/or area.

Chimney, Venting, Burner area and all other important areas of the fireplace shall be kept in good condition and clean.

The height of the chimney vent must extend a minimum of 2ft. above the highest point where it passes through the roof for Vertical Termination.

The access door area of the fireplace may be hot to touch for normal operational activities. Please turn off the fireplace and let it cool down before performing any operation over hot surfaces.

TABLE OF CONTENTS

APPENDIX-A

1. General Information.....	Page 1
2. Letter From the President.....	Page 2
3. Fireplace Component Breakdown.....	Page 3
4. Rating Plate.....	Page 4
5. Installation Requirements.....	Page 5
6. Vertical Termination.....	Page 6
» Fireplace Specifications.....	Page 7
» Anchor options diagram.....	Page 9
» Clearance to Combustibles.....	Page 10
» Enervex Electrical diagram.....	Page 11
7. Horizontal Termination.....	Page 12
» Fireplace Specifications.....	Page 13
» Anchor options diagram.....	Page 15
» Clearance to Combustibles.....	Page 16
» Enervex Electrical diagram.....	Page 17
8. Fireplace Installation.....	Page 18

APPENDIX-B

1. Burner Installation Operation.....	Page 27
2. Lighting Instructions.....	Page 28
3. Chimney Venting Installation & Operation.....	Page 29
4. Cleaning Maintenance.....	Page 32
5. Replacements & Closing.....	Page 33
6. Warranty.....	Page 34
7. Enervex Intelli Draft System.....	
» ADC100 w/ PDS-I	
» Automatic Damper	
» Power Exhaust Fan	

APPENDIX-A

GENERAL INFORMATION

KEEP THIS MANUAL HANDY FOR EASY REFERRAL.

All **NOTES, WARNING,** and **CAUTION** statements will appear in bold font and/or uppercase letters: **THEY SHOULD BE STRICTLY OBSERVED.**

This installation manual is to serve as a guidebook to the installation of your fireplace system. It is not intended to replace skilled trades and/or expertise that may be required to perform installations. All chimney components must be installed by qualified persons in accordance with local building codes and chimney and vent system manuals. Components described herein are intended as an indication of the components required and/or supplied.

All standard safety practices as indicated by local codes, laws, or OSHA standards must be followed to prevent accident or injury. Some of the components supplied cannot be installed by a single person nor should they be installed from a ladder. All site safety arrangements are the responsibility of the Site Supervisor, General Contractor and/or Fireplace Installers, and not CF + D.

USING MAKE-SHIFT COMPROMISES DURING INSTALLATION CAN CAUSE DAMAGE.

Such an installation is not covered under CF + D limited warranty.

DO NOT CONNECT TO ANY AIR DISTRIBUTION DUCT OR SYSTEM!

CF + D specializes in creating one-of-a-kind, hand-made artistic fireplaces. While these fire features are generally developed for their aesthetic presence they are also a functional heating appliance. As such, natural variations in the material forming processes and patina are part of the sculptural spirit of the fireplace, adding to the beauty and uniqueness of the design.

Thank you for choosing **CF + D** | Custom Fireplace Design

A LETTER FROM OUR PRESIDENT

CF + D | custom fireplace design

Quality Creativity Innovation

Our entire team joins me in thanking you for purchasing this LUCIJA | Suspended Gas Fireplace, designed and manufactured by **CF + D** | custom fireplace design. We are proud of our quality workmanship, our creativity in designing functional art pieces and our commitment to technical innovation. We welcome the challenges that come across our designers' desks, keeping our creative minds working on developing new ideas with our clients to build their dream fire feature.

Upon receiving this letter your fireplace has now been shipped and received. The installation, technical and service manuals are included in the package and our Technical Team is available with assistance throughout the installation and start-up of your new fireplace.

The Management, Designers and our Metal Craftsman, thank you again for the opportunity of being a part of your project. We value our clients greatly and are available for consultation before, during and after the installation of your fireplace.



Vince Volpe
President and CEO
CF + D | custom fireplace design

FIREPLACE COMPONENT BREAKDOWN

LUCIJA | Suspended Gas Fireplace

BURNER SYSTEM

Model	Manufacturer	Listed to/Certified by:
PB-16 w/EPK-1	RH Peterson	ANSI Z21.60-2012/CSA 2.26-2012

BURNER CHARACTERISTICS

Description	Natural Gas	Liquid Propane
BTU's	45000	40000
Min. Input pressure supply	7" of water column	11" of water column
Max. Input pressure supply	10.5" of water column	13" of water column
Manifold pressure	3.5" of water column	10" of water column

CHIMNEY SYSTEM

Component	Manufacturer	Listed to/Certified by:
6" ID B-Vent	DuraVent/Don park	UL 441 and ULC S605

VENTING SYSTEM

Energex Intelli Draft System

Components	Description	Listed and Certified by:
Automatic Damper Control	ADC 100	UL 508/CSA C22.2 No. 14-05 Certified
Automatic Damper	6" ADM	UL listed
Proven Draft Switch (Pressure Sensor)	PDS-1	UL 508/CSA C22.2 No. 14-05 Certified)
Power Fan	RS009	UL 378 CSA-CAN3-B255-M81 Certified

WEIGHT TABLE

Anchor assembly weight (24" long)	85 lbs. approx.
Flue & Hood assembly weight	100 lbs. approx.
Fireplace body Weight	150 lbs. approx.
Each add'l. 1 ft. of flue pipe weighs 11 lbs. approx.	
Each add'l. 1 ft. of anchor pipe weighs 17 lbs. approx.	

RATING PLATE



CF + D | custom fireplace design

5230 Harvester Rd., Unit B2 Burlington, ON L7L 4X4

Ph: 905-681-3070 Toll: 1-866-909-3070

Fireplace has been tested and proved to comply with ANSI Z21.50-2019 • CSA 2.22-2019 Vented Decorative Gas Appliances. Certified under ICC-ES PMG-1290 Made in Canada

MODEL: **PMG-1290-LUCIJA**

SERIAL: XXXX

**VENTED GAS FIREPLACE; NOT FOR USE WITH SOLID FUEL.
FOR USE WITH GLASS DOORS CERTIFIED WITH THE APPLIANCE ONLY.
NOT CERTIFIED FOR MOBILE HOMES.**

This appliance must be installed in accordance with local codes, if any; if none, follow ANSI Z223.1/NFPA 54, or CSA B149.1. This appliance is only for use with the type of gas indicated on the rating plate and may be installed in an aftermarket, permanently located, manufactured home (USA only) or mobile home, where not prohibited by local codes. See owner's manual for details. This appliance is not convertible for use with other gases.

WARNING: Improper Installation, adjustment, alteration, service, or maintenance can cause injury or property damage. Refer to the owner's information manual provided with this appliance. For assistance or additional information consult a qualified installer, service agency or the gas supplier.

CAUTION: Hot while in operation. Do not touch. Severe burns may result. Keep children, clothing, furniture, gasoline, and other liquids having flammable vapors away. Appliance. For assistance or additional information, consult a qualified installer, service agency, or the gas supplier.

CLEARANCE TO COMBUSTIBLES: 12" around the fireplace, 12" from floor to bottom of the unit, 1" around flue and anchor assembly must be maintained to prevent fire, injury and damage to property.

Certified with Enervex Intelli System (Power Vent Exhaust System). For use only with automatic vent damper device Part No. 201.0000.1206 follow installation instructions.

Total Electrical Input "Less than 12 amperes."

BURNER IDENTIFICATION

Manufacturer	:- RH PETERSON
Type of fuel	:- XXXX
BTU's	:- XXXX
Min. Input pressure supply	:- XXXX
Manifold pressure	:- XXXX
Max. Input pressure supply	:- XXXX

INSTALLATION REQUIREMENTS

A) Installation Requirements

- Prepare the installation location for the fireplace.
- **KEEP PACKAGING AND FOAM** on the unit until installation is complete. Once the installation is complete, remove the rest of the packaging material. Remove packaging **ONLY** from the end of the fireplace flue collar for installation.
- Small marks and smudges may be touched up with supplied touch-up paint if necessary.



CAUTION!

BEFORE INSTALLATION ensure that you have read and understood all provided manuals and drawings.

Required tools

- 3/16" Drill Bit
- 5/32" Allen key
- 1/8" Allen key
- Level
- Deep socket & Ranch set (3/4" Specifically)
- Scaffolding if necessary
- Hammer
- Lifting device
- 2 person minimum is required for installation.

CAUTION

**TWO OR MORE PEOPLE
OR A LIFTING DEVICE
REQUIRED TO LIFT
THIS ITEM**

B) Electrical & Gas Connection Requirements

NOTE: The Enervex Intelli Draft Power Vent System electrical installation must be completed **BEFORE** installing your fireplace!



CAUTION!

The Enervex Intelli Draft Power Vent System must be **CONNECTED AND FUNCTIONAL BEFORE** the burner can be lit!



WARNING!

DO NOT CONNECT THIS UNIT TO A CHIMNEY FLUE SERVING ANOTHER APPLIANCE.

NOTE : The gas line connection may be made using 1/2" rigid tubing or an approved flex connector. Since some Municipalities have additional local codes it is always best to consult your local authorities and the current edition of the National Fuel Gas Code ANSI. Z223.1, NFPA54. In Canada CAN/CGA-B149 (1 or 2) Installation Code.

Electrical dedicated switch operation recommended for all applications.

It is the responsibility of the customer to have enough slack of gas line for connection at fireplace body. The electrical wire provided by CF + D for Burner controls connection will have enough slack to meet your ceiling height requirements.

1 ft. additional Slack of Gas line required at the ceiling for possible service and maintenance needs.

The manual further covers instructions on Horizontal Venting Termination & Vertical Venting Termination. Follow the instructions for the termination that suits best to your application. Refer to the layout drawings provided before where appropriate.

VERTICAL TERMINATION

FIREPLACE SPECIFICATIONS

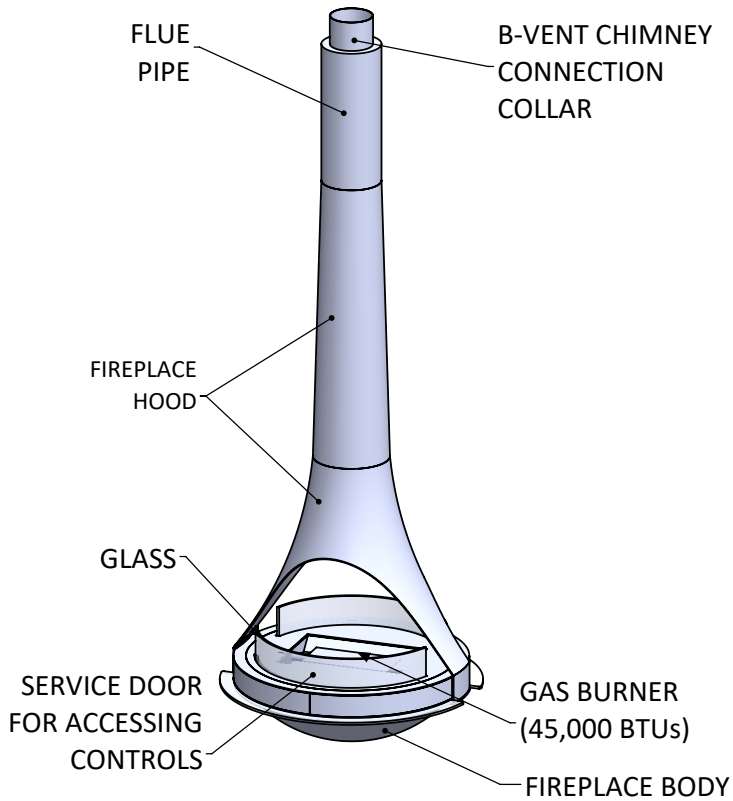
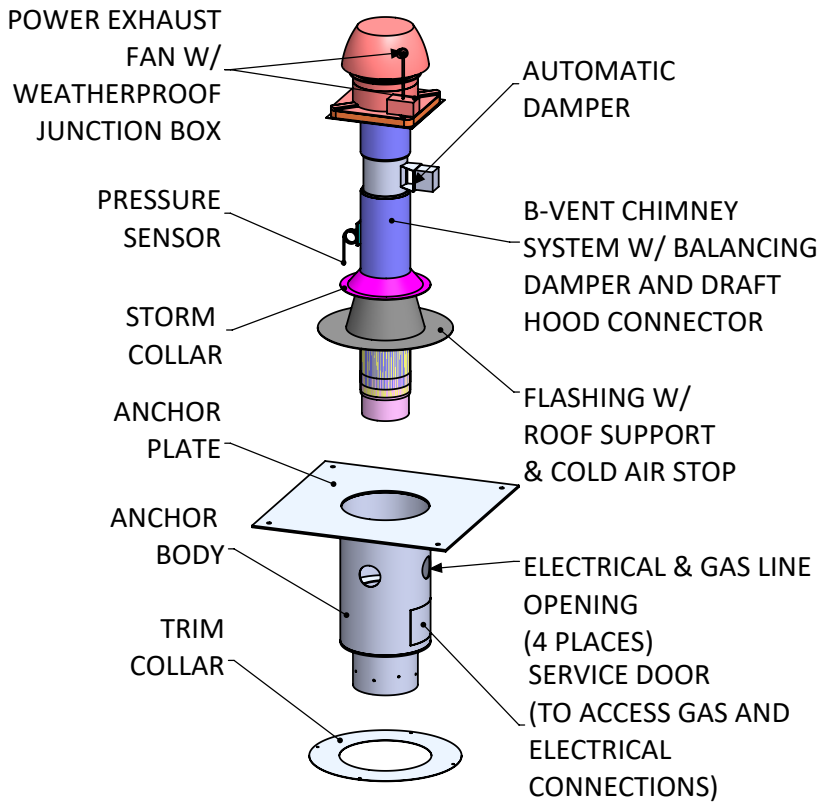

EXPLODED VIEW

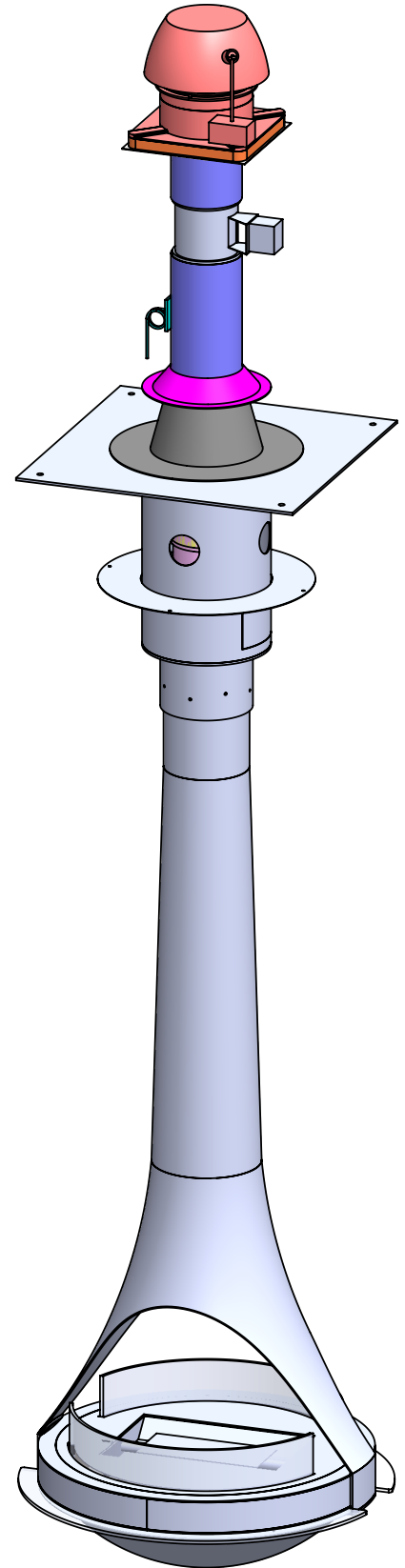

ASSEMBLY VIEW

FIREPLACE SPECIFICATIONS

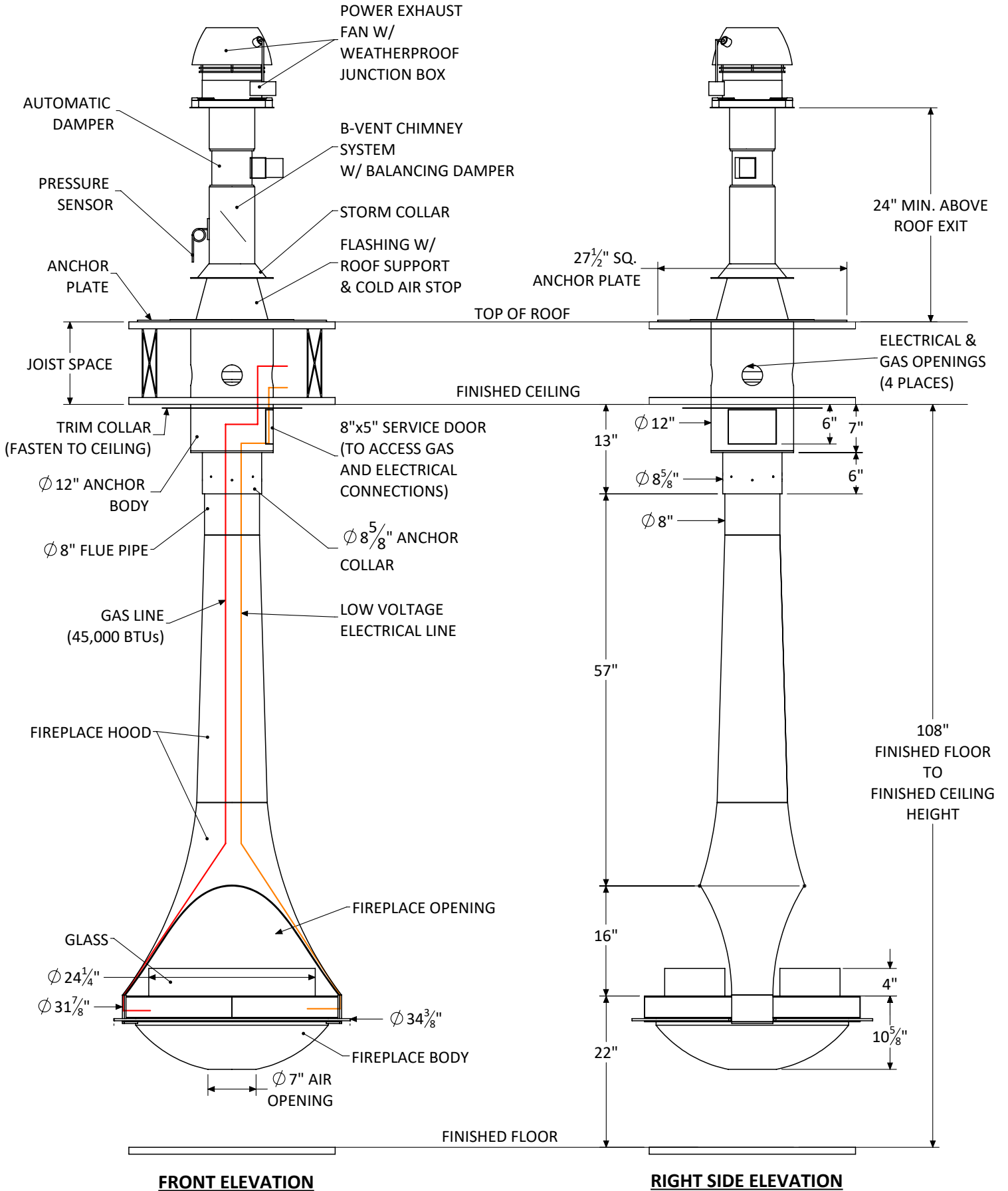

ANCHOR OPTIONS DIAGRAM

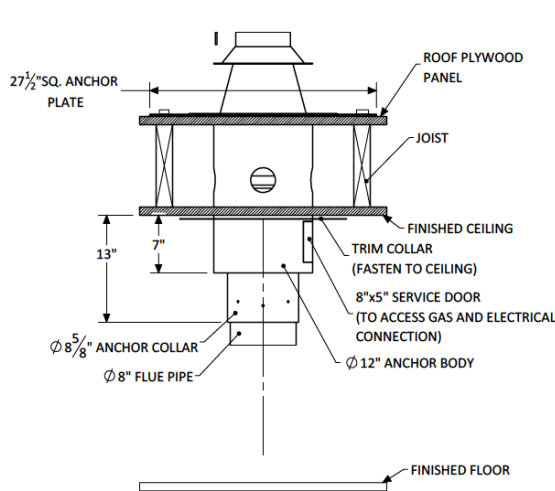

OPTION A - FLAT ROOF DROP FROM ABOVE

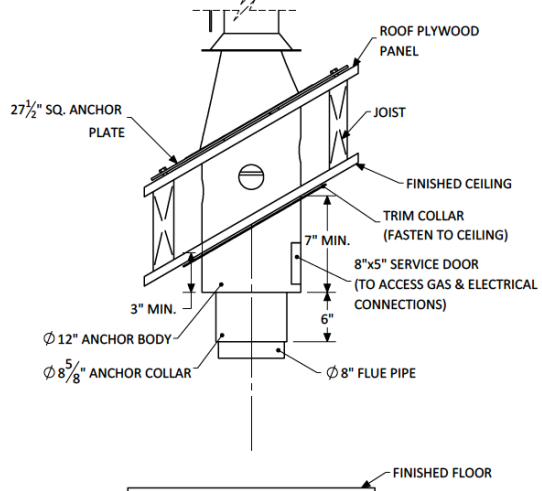

OPTION B - SLOPED DROP FROM ABOVE

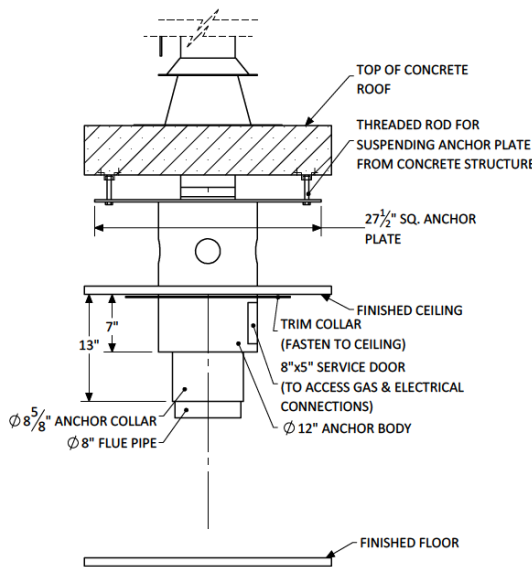

OPTION C - SUSPENDED FROM CONCRETE

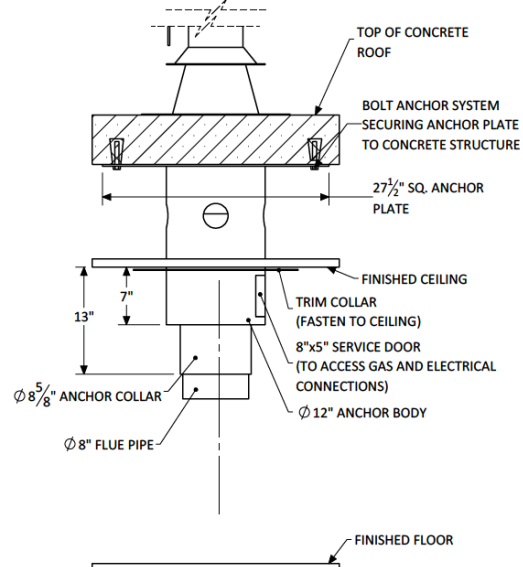

OPTION D - ATTACHED BELOW CONCRETE

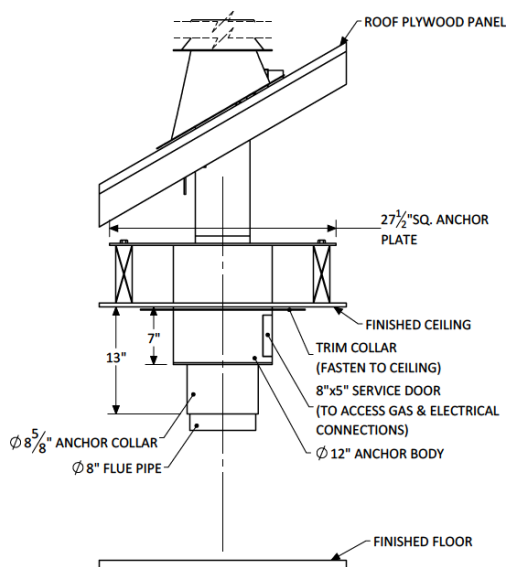

OPTION E - SLOPED ROOF FLAT CEILING ANCHOR DROPPED ON ROOF

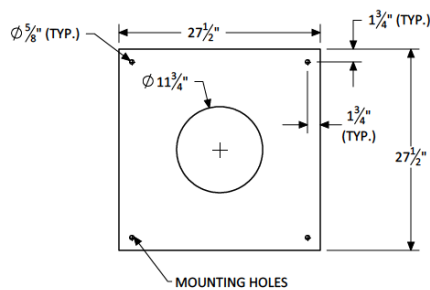

STANDARD ANCHOR PLATE- 1/4" THICK.

CLEARANCE TO COMBUSTIBLES



NOTE: WHEN POSITIONING THE FIREPLACE,

- **A MINIMUM 12" DISTANCE BETWEEN A COMBUSTIBLE WALL AND FIREPLACE BODY IS REQUIRED.**
- **1" WHERE THE ANCHOR OR FLUE CROSSES THE CEILING & ROOF.**
- **12" FROM FLOOR TO THE BOTTOM OF THE FIREPLACE.**
- **CLEARANCES MUST BE MAINTAINED FROM ANY COMBUSTIBLE MATERIAL.**
- **FIRE AND PROPERTY DAMAGE MAY OCCUR IF THIS CLEARANCE IS NOT MAINTAINED.**

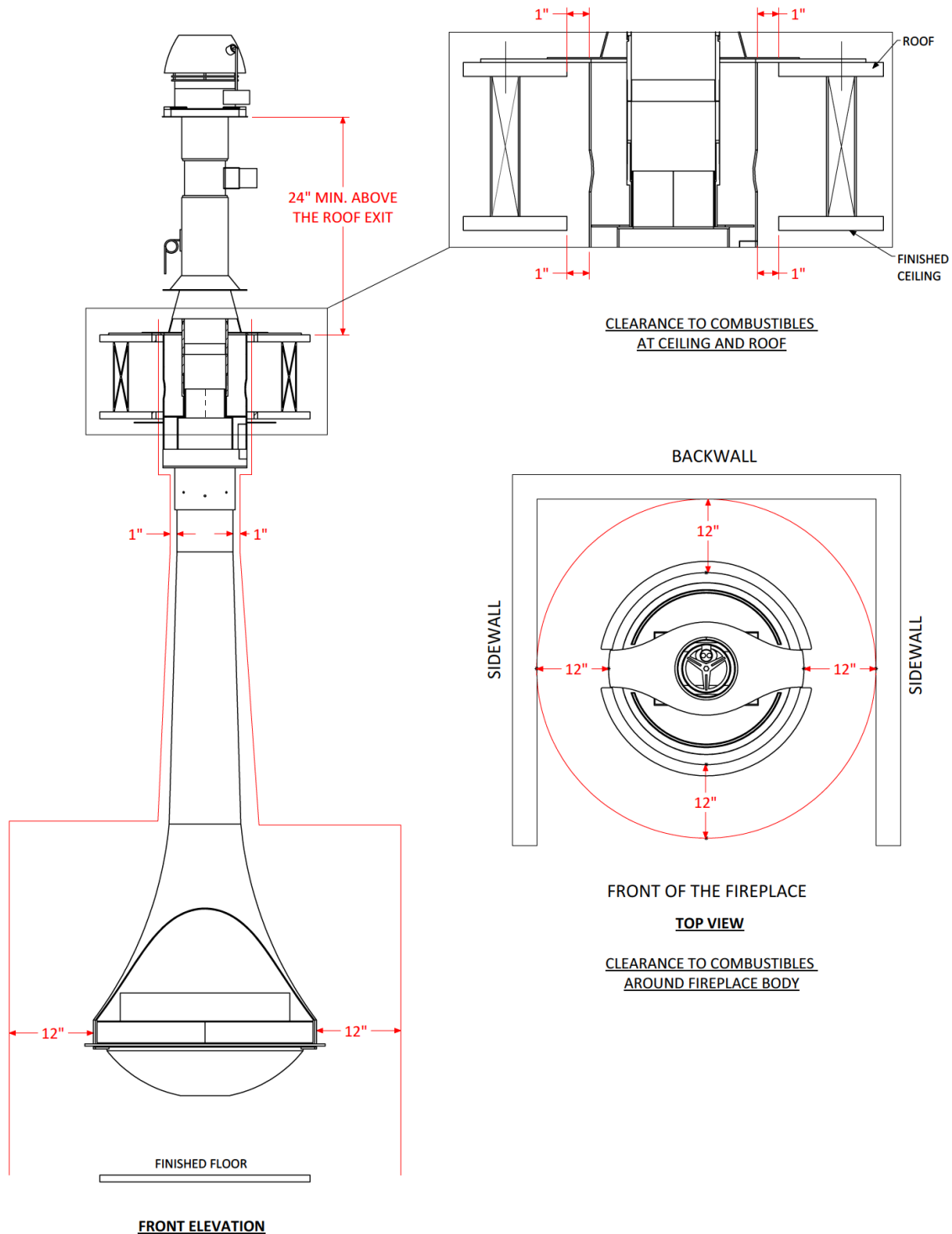

ENERVEX ELECTRICAL DIAGRAM

TYPICAL VITA GAS ENERVEX ELECTRICAL DIAGRAM

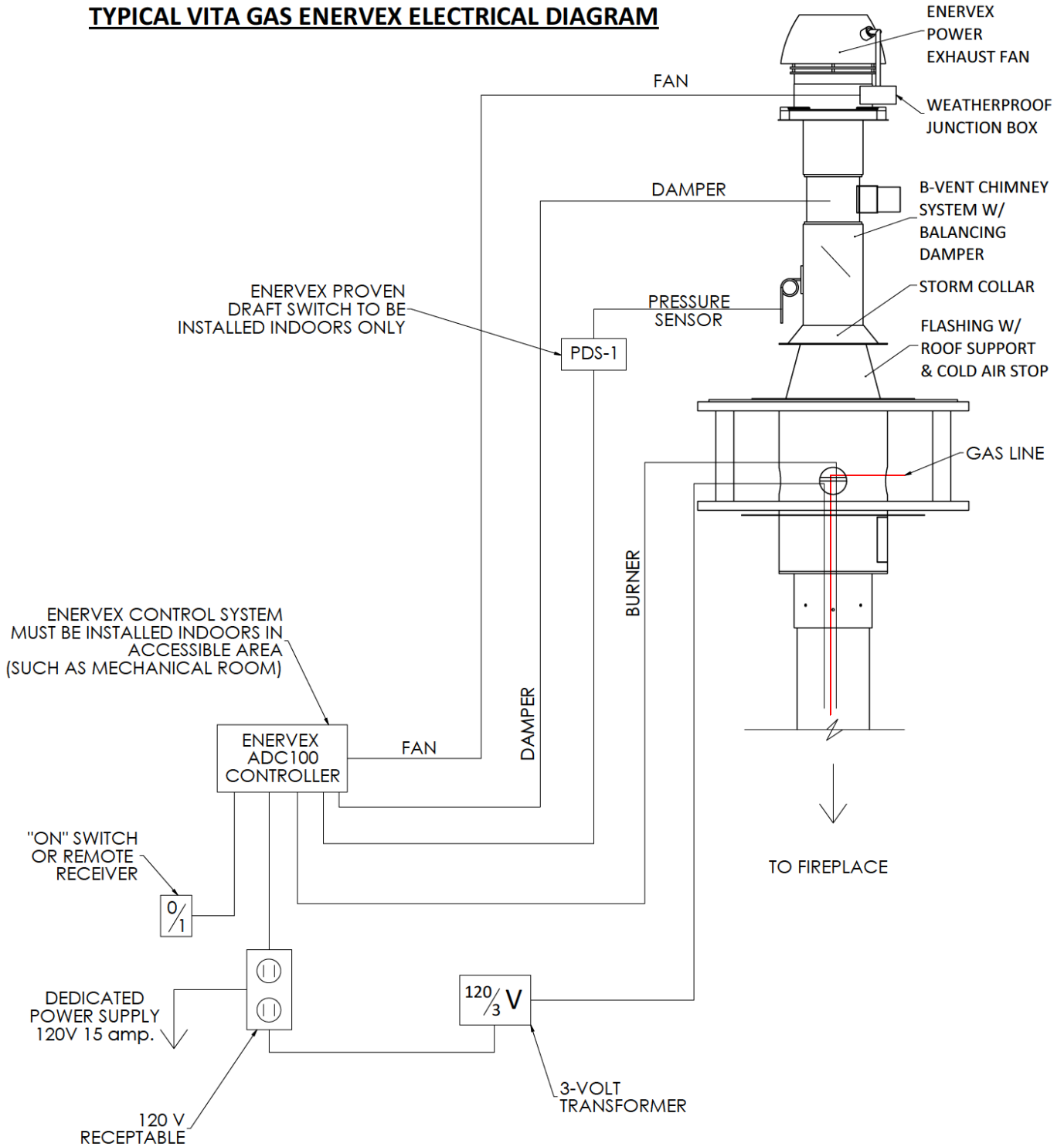

**SCHEMATIC ENERVEX SYSTEM
AS PER ENERVEX MANUALS/MEP
REQUIREMENTS**

**SEE PAGE 11 OF ENERVEX ADC100
MANUAL**

HORIZONTAL TERMINATION

FIREPLACE SPECIFICATIONS

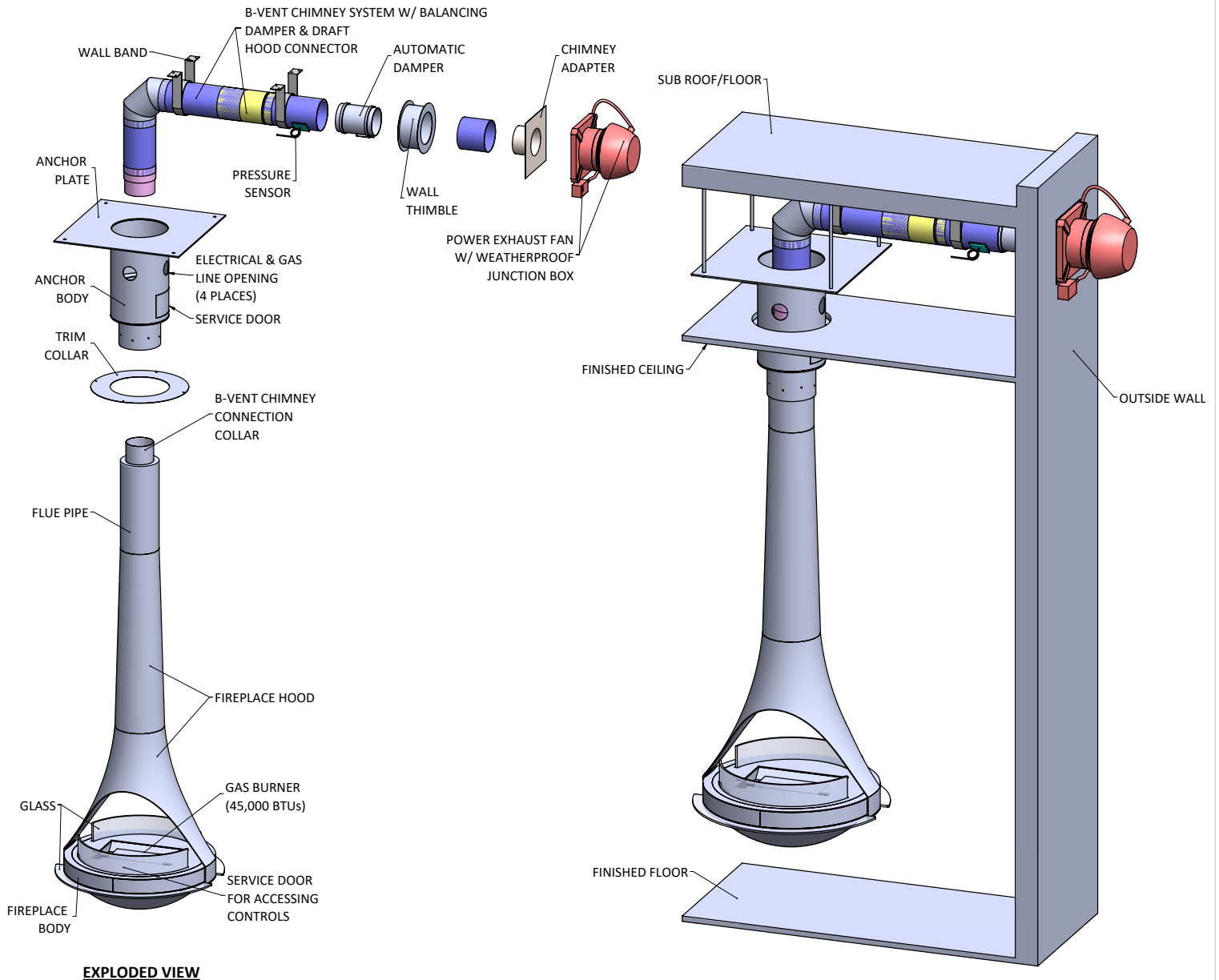

FIREPLACE SPECIFICATIONS

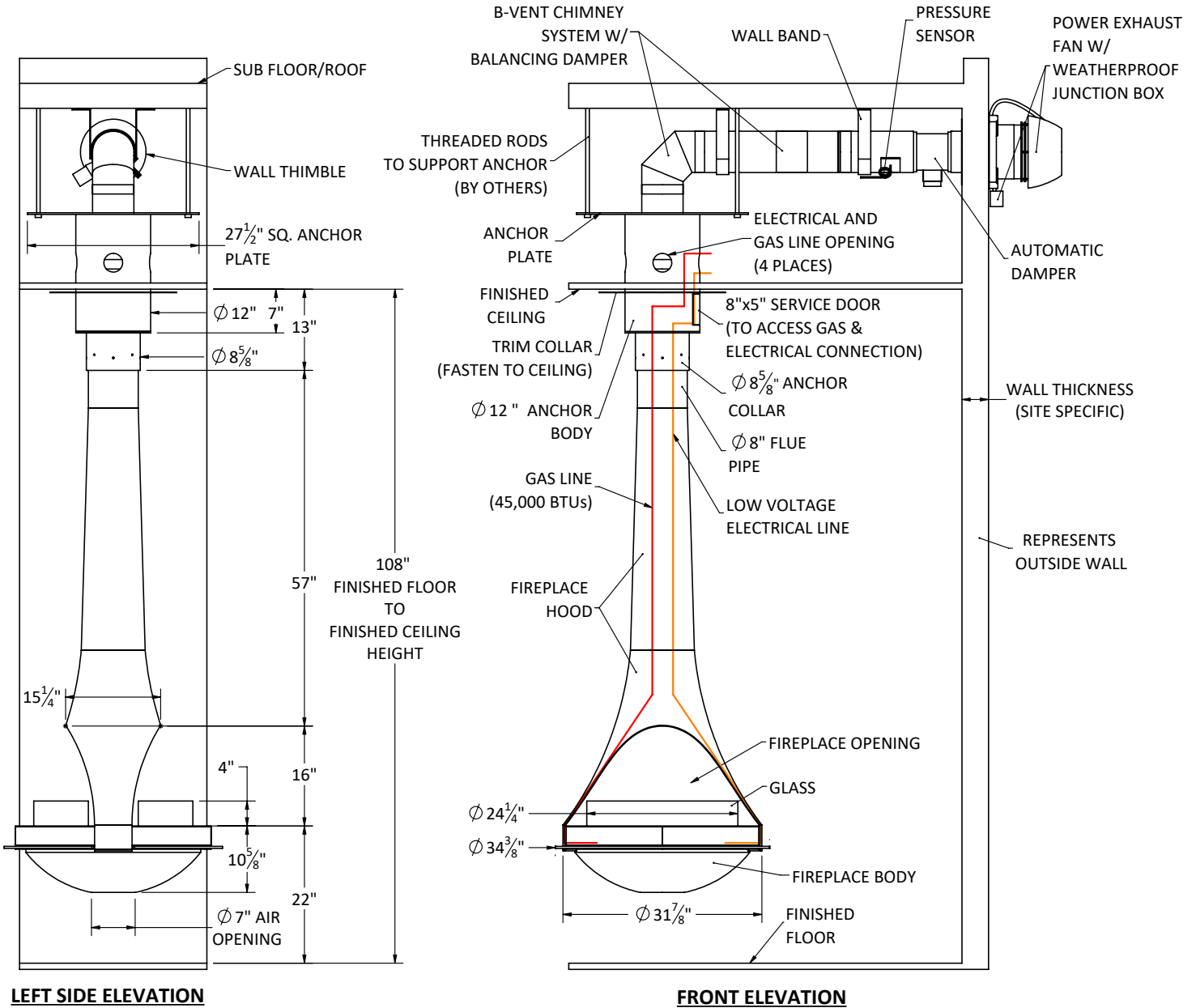

ANCHOR OPTIONS DIAGRAM

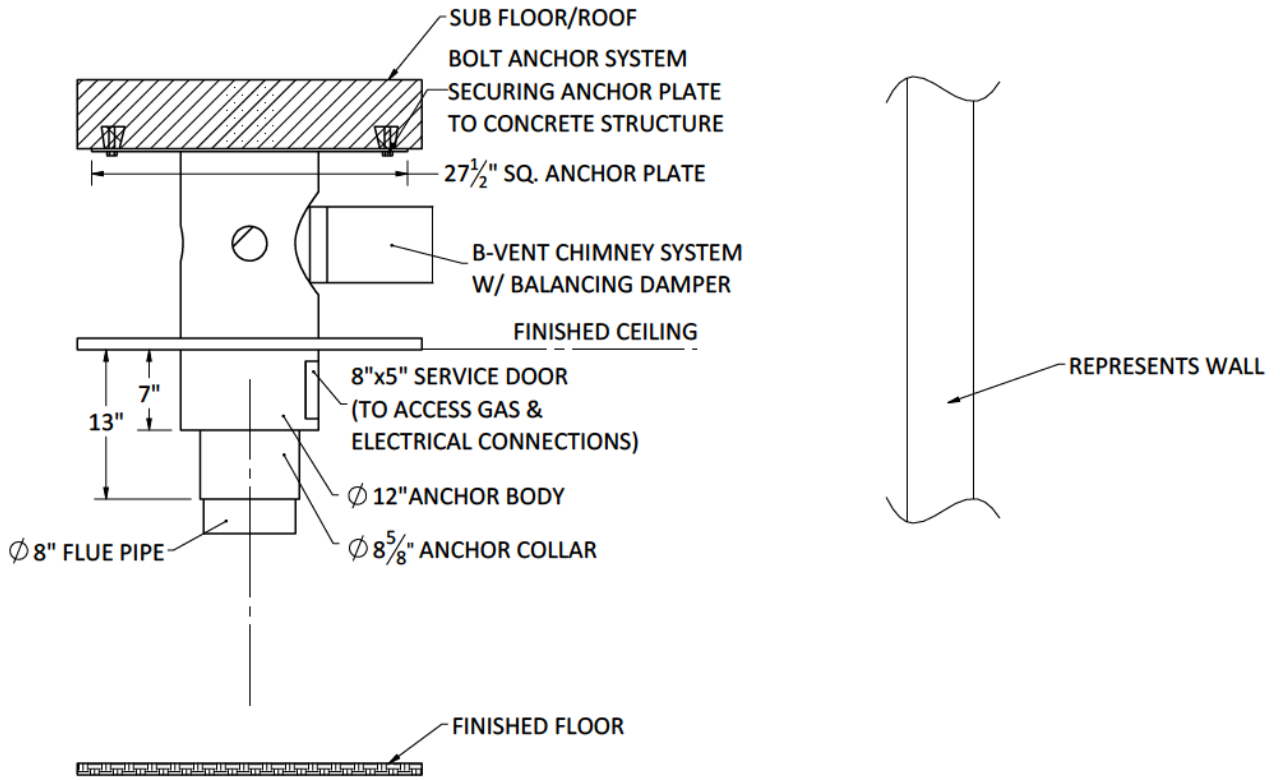

OPTION A - ATTACHED BELOW CONCRETE

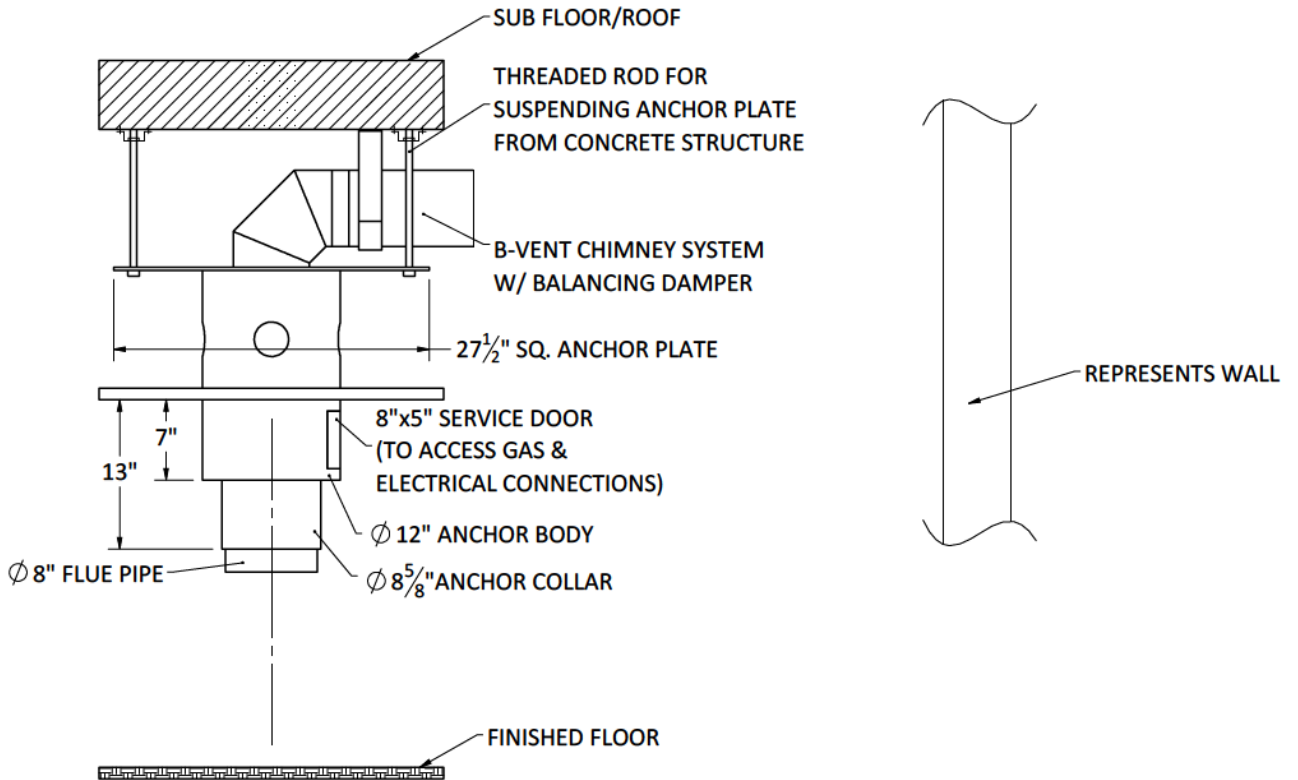

OPTION B - SUSPENDED FROM CONCRETE

CLEARANCE TO COMBUSTIBLES



NOTE: WHEN POSITIONING THE FIREPLACE A MINIMUM OF

- **12" DISTANCE BETWEEN A COMBUSTIBLE WALL AND FIREPLACE BODY IS REQUIRED,**
- **12" FROM BOTTOM OF THE FIREPLACE TO THE FLOOR**
- **1" WHERE THE ANCHOR OR FLUE CROSSES THE CEILING & ROOF.**
- **1" WHERE THE CHIMNEY SYSTEM TERMINATES AT WALL OUTLET**
- **CLEARANCES MUST BE MAINTAINED FROM ANY COMBUSTIBLE MATERIAL.**
- **FIRE AND PROPERTY DAMAGE MAY OCCUR IF THIS CLEARANCE IS NOT MAINTAINED.**

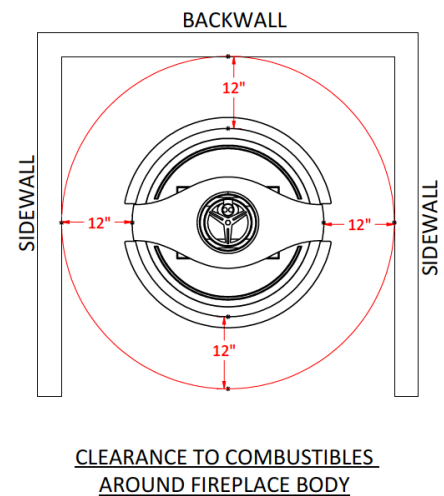
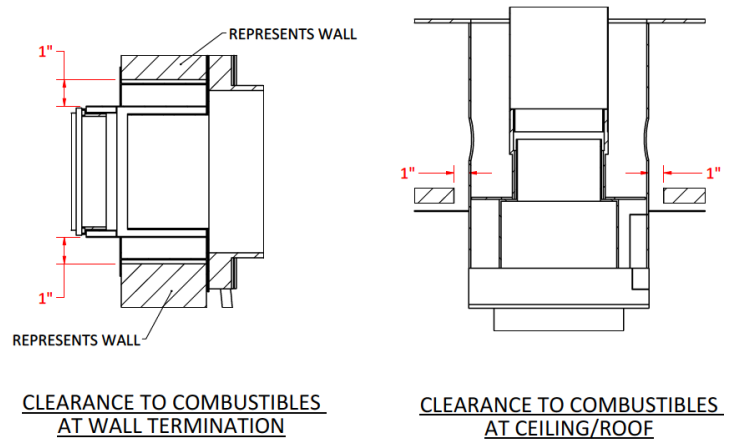
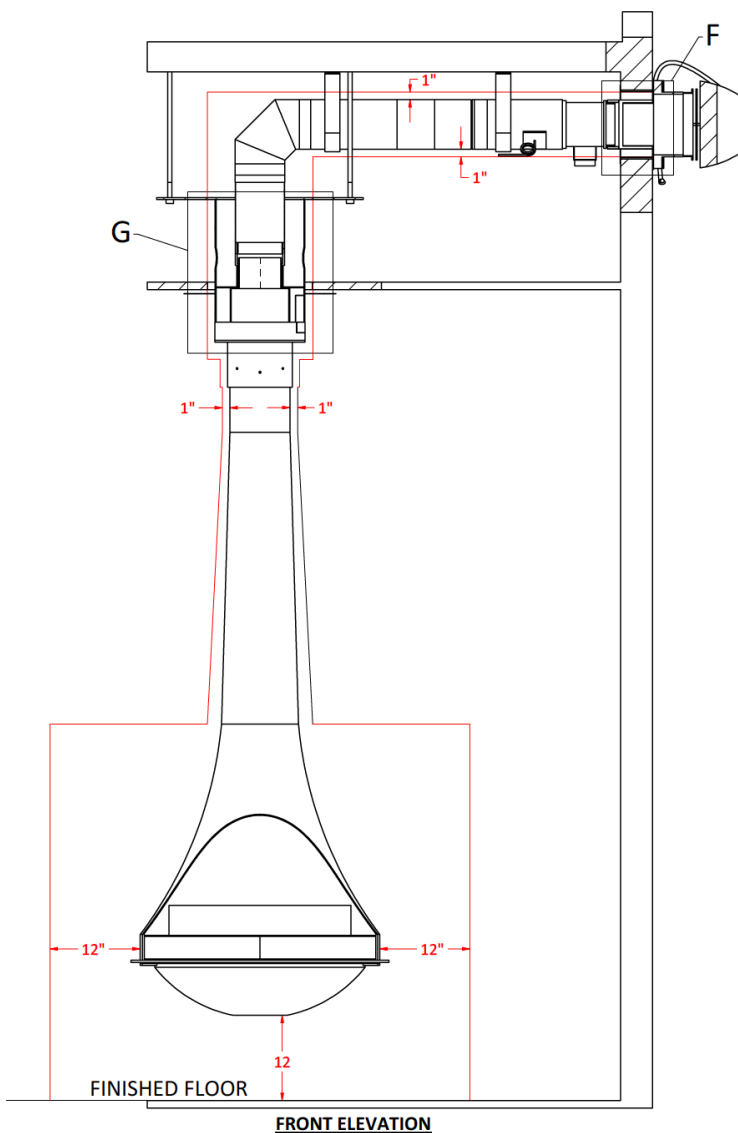

ENERVEX ELECTRICAL DIAGRAM

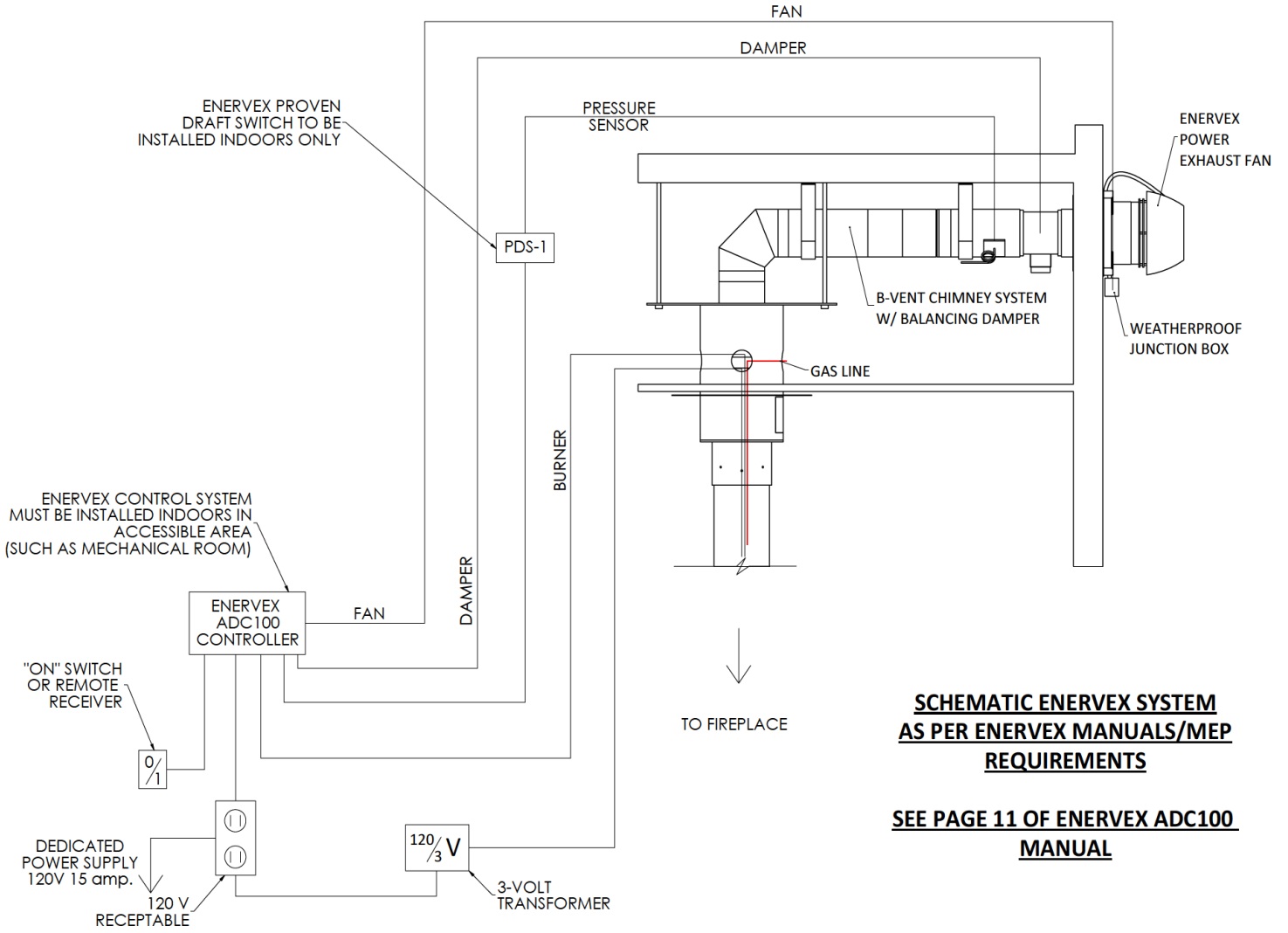

**SCHEMATIC ENERVEX SYSTEM
AS PER ENERVEX MANUALS/MEP
REQUIREMENTS**

**SEE PAGE 11 OF ENERVEX ADC100
MANUAL**

FIREPLACE INSTALLATION

I. Install the Anchor Assembly

The anchor is the first piece to be installed, it will hold the weight of the flue pipe, and the fireplace body while suspending the unit from the ceiling or roof. The chimney system builds up from the anchor. The flue and fireplace body is suspended from the anchor. The anchor assembly is mounted and supported by the support frame constructed solely for this purpose. A supported opening in the roof or ceiling to accommodate the anchor assembly will be required. Adequate and approved structural methods must be used when mounting the anchor for it to carry its designated load.



CAUTION!

THE SUPPORT OF THE ANCHOR ASSEMBLY (ROOF STRUCTURE, SLAB, ETC.) MUST BE SIZED IN ACCORDANCE WITH THE STATIC AND DYNAMIC LOADS OF THE FIREPLACE. THE SIZE CALCULATION FOR THE SUPPORT IS NOT THE RESPONSIBILITY OF CF + D OR ITS AFFILIATES. IT IS YOUR RESPONSIBILITY TO CONSULT WITH AN ENGINEER OR ARCHITECT FOR YOUR PROJECT.

Before starting, verify the location of the flue pipe and fireplace body. Also, verify the point at which the anchor assembly will be positioned. Lift the anchor assembly into a position to be placed in the prepared supported ceiling or roof. Depending on your application refer to your specific layout drawing for custom anchor plate installation (See *Anchor Options Diagram Page # 9 & 15*).

The anchor for a fireplace with internal gas lines has been manufactured with an access door in the anchor body, which will be visible below the finished ceiling line. Install the anchor so that the access door is facing what will be considered the side of the fireplace. Where the roof is sloped, this orientation will have been designed into the anchor.

Place the anchor in the desired location and mount it on the support structure using $\frac{1}{2}$ " screws/bolts (*Figure 1 & 2*). Screws must be mounted into studs or solid substrate.

The anchor assembly shall be secured in place and the flue pipe should hang level and straight.

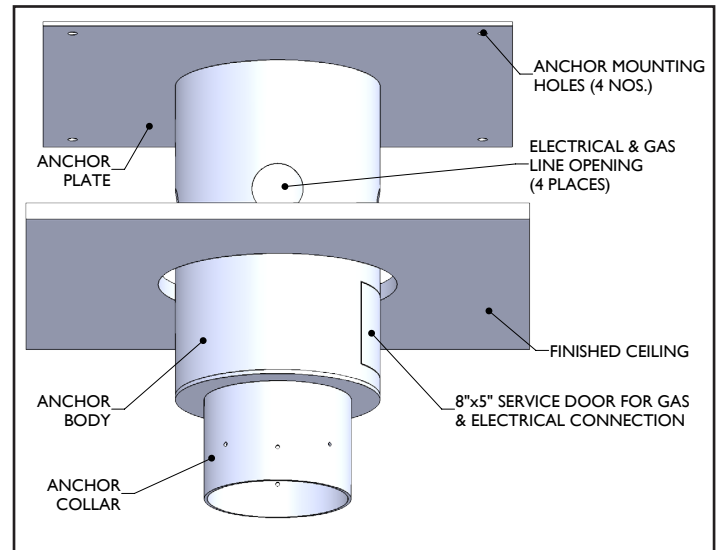

Figure.1 - Represents Flat Anchor

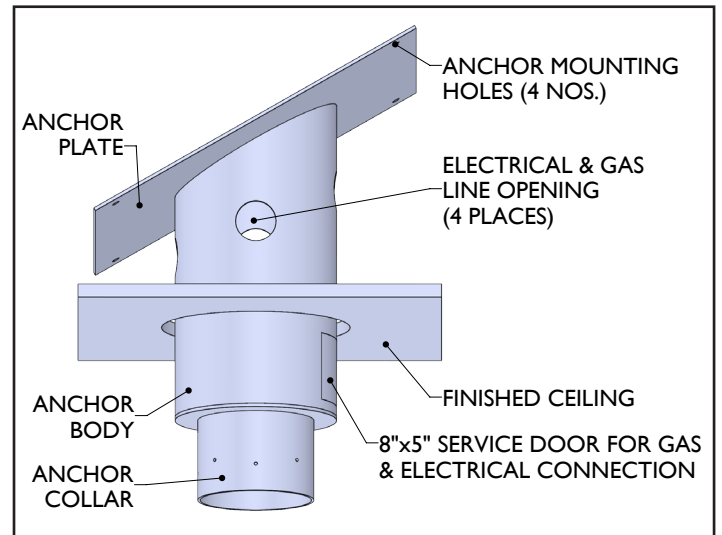

Figure.2 - Represents Sloped Anchor

FIREPLACE INSTALLATION

2. Install the Trim Collar

Fit the trim collar around the Anchor pipe and slide it upwards to meet the finished ceiling. Affix the trim collar to the finished ceiling either by using 4 screws (*not provided*), or other means of attachment depending on your requirements. (See Figure 3 & 4.)



NOTE: You will not be able to install the trim collar once the fireplace body has been attached!

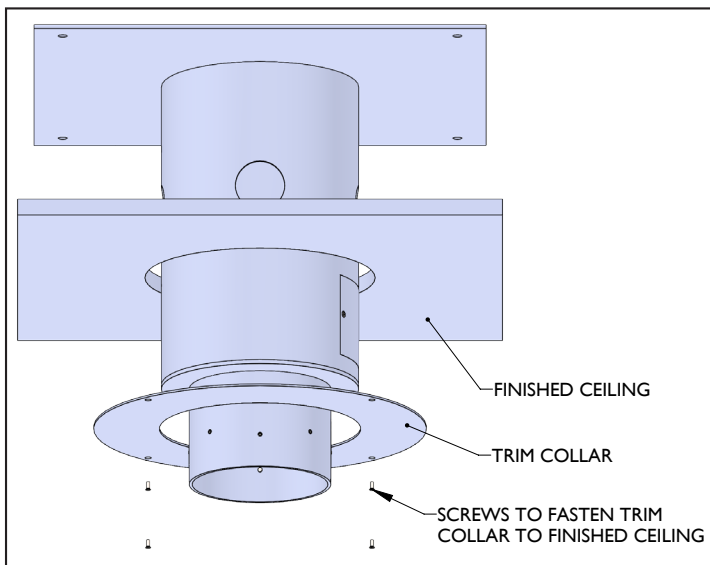

Figure.3

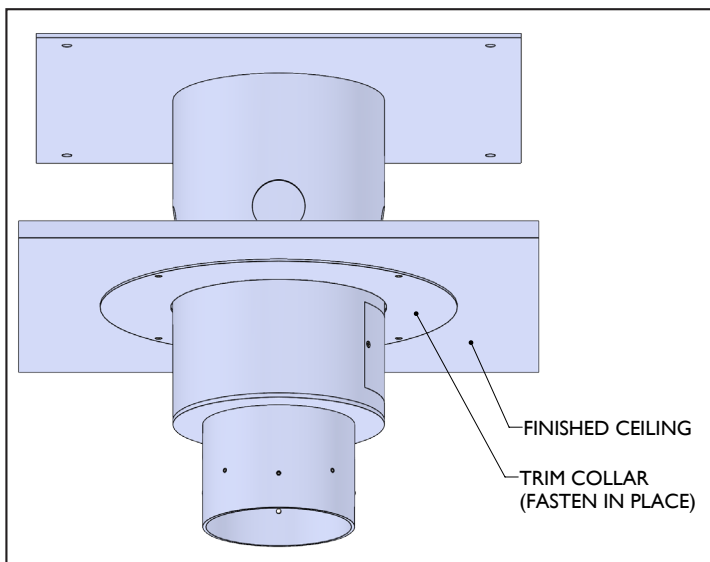

Figure.4



NOTE:

IF THE CEILING HEIGHT IN YOUR APPLICATION IS MORE THAN THE CF + D's STANDARD CEILING HEIGHT APPLICATION, YOU MAY HAVE BEEN SUPPLIED WITH MULTIPLE FLUE SECTIONS. PLEASE FOLLOW STEPS 5 & 6 BEFORE PERFORMING THE STEP 4 FIREPLACE BODY INSTALLATION. USING YOUR LAYOUT DRAWING AS A GUIDE, REVIEW THE NUMBER OF FLUE PIPES YOU HAVE BEEN SUPPLIED WITH AND ENSURE THAT YOU ARE INSTALLING THEM IN THE CORRECT ORDER. PLEASE REFER TO STEP 3 INSTALL THE FLUE PIPE FOR INSTALLING THE FIRST PIECE OF FLUE PIPE INTO THE ANCHOR BODY. THE FIRST SECTION OF FLUE PIPE WILL HAVE A REDUCTION COLLAR FOR CHIMNEY VENTING INSTALLATION. (SEE FIGURE -5)

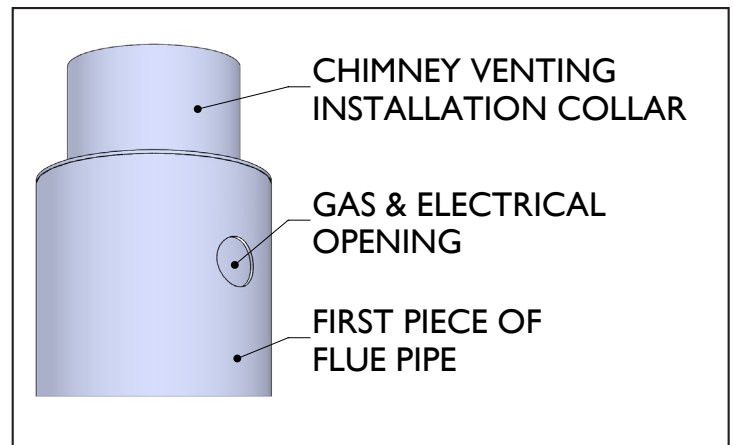

Figure.5

IF THE CEILING HEIGHT IN YOUR APPLICATION IS WITHIN THE CF + D's STANDARD CEILING HEIGHT APPLICATION, YOU MAY HAVE BEEN ONLY SUPPLIED WITH ONE SECTION OF FLUE PIPE. THE TOP OF THAT FLUE PIPE WILL HAVE SAME DETAILS AS SHOWN IN FIGURE - 5. PLEASE PROCEED TO STEP 3 INSTALL THE FLUE PIPE.

FIREPLACE INSTALLATION

3. Install the Flue Pipe

Remove the anchor service door. Install the flue pipe into the anchor body, ensuring that the gas line conduit inside the flue pipe lines up with the access opening on the anchor body. The flue pipe have already been cut to the proper installation length.

NOTE: There are 8, pointed load bearing set screws installed into the anchor body and 2 stainless split pins included in the package. The 8 set screws are staggered in position. Begin by loosening each set screw in the anchor body to maximize space for the flue pipe to enter the anchor.

Raise the flue pipe up to meet the anchor body that has now been positioned. The flue pipe is designed to fit directly into the anchor body (See *Figures 6 & 7*).

Use a $\frac{5}{32}$ Allen key to tighten one screw until resistance is felt, then tighten the screw directly opposite on the other side of the flue until resistance is felt and continue.

When all 8 screws are half tightened, check the position of the flue pipe and continue adjusting until perfectly straight and level. Once the flue is in perfect position, completely tighten each of the 8 set screws firmly securing the flue pipe into the anchor.

Locate the two $\frac{1}{8}$ " pilot holes directly opposite each other in the anchor body. Once the cramping screws have been tightened, the two stainless steel split pins (provided) must be inserted into the anchor collar.

There are two holes drilled into the anchor collar. The mating holes are not pre-drilled and will require drilling at site.

Using the holes in the anchor as guides, pass a $\frac{1}{8}$ " drill bit through each pilot hole and through the flue pipe.

Carefully hammer the split pins into place through the anchor wall into the flue pipe until flush which will permanently lock the flue pipe to the anchor.

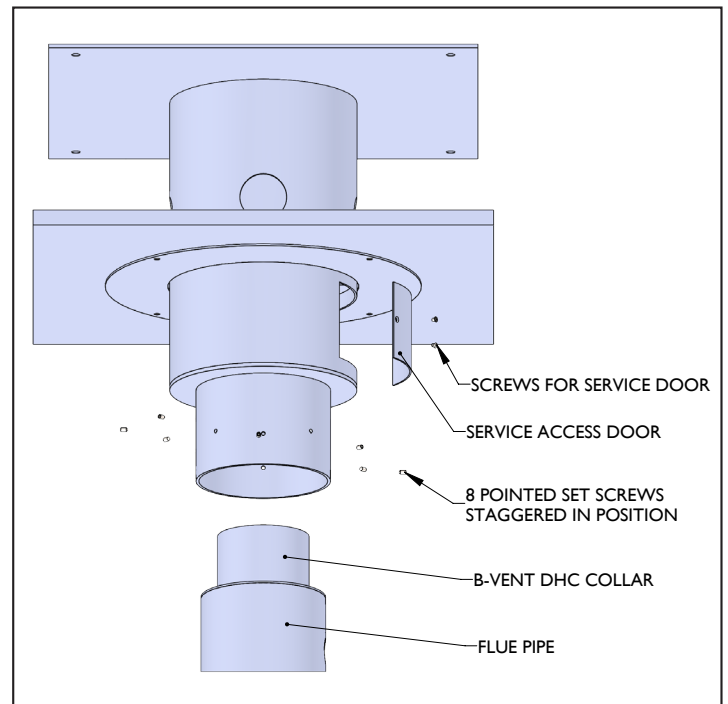

Figure.6

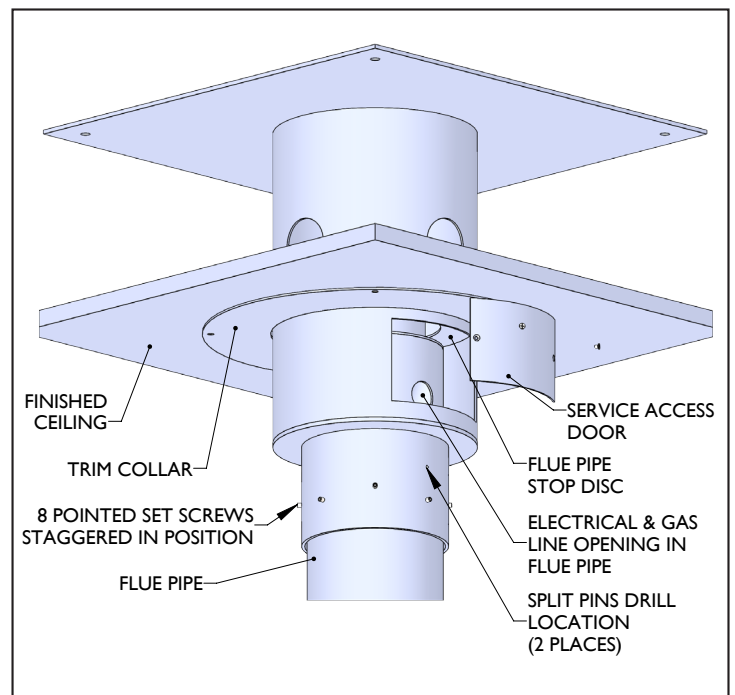

Figure.7

FIREPLACE INSTALLATION

4. Install the Fireplace Body

There are alignment marks on the flue and the fireplace body right at the seam on the rear. Align these marks when installing the fireplace body to the flue at what would be considered the rear of the application. The Flue Pipe contains the Gas/Electrical Conduit for Gas Fireplace. Ensure that the Gas/Electrical Conduit is in the correct position for the Fireplace Unit.

NOTE: ENSURE THAT YOU HAVE READ YOUR MANUAL TO AVOID DAMAGE TO THE FIREPLACE BODY! This operation will require multiple people.

Feed the flexible gas line down through the conduit in the flue pipe and hole in the anchor stop plate and through to the access door in the anchor.

Ensure that the flexible gas line runs through the conduit in the flue pipe and has slack to make the connection to the burner gas line already installed in the fireplace body.

Using an appropriate lifting device, raise the fireplace body up towards the flue pipe until the flexible gas line in the fireplace body can be connected to the flex-line from the flue pipe.

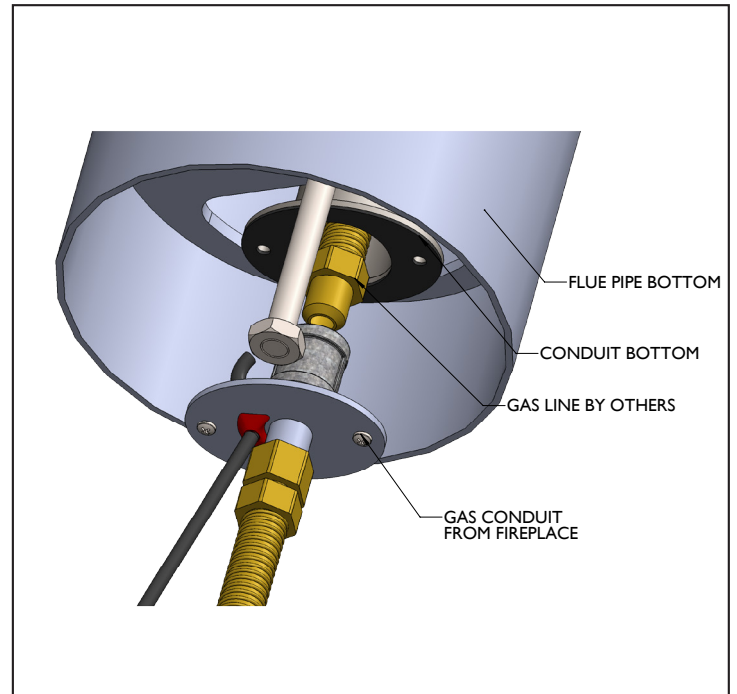

Figure.9

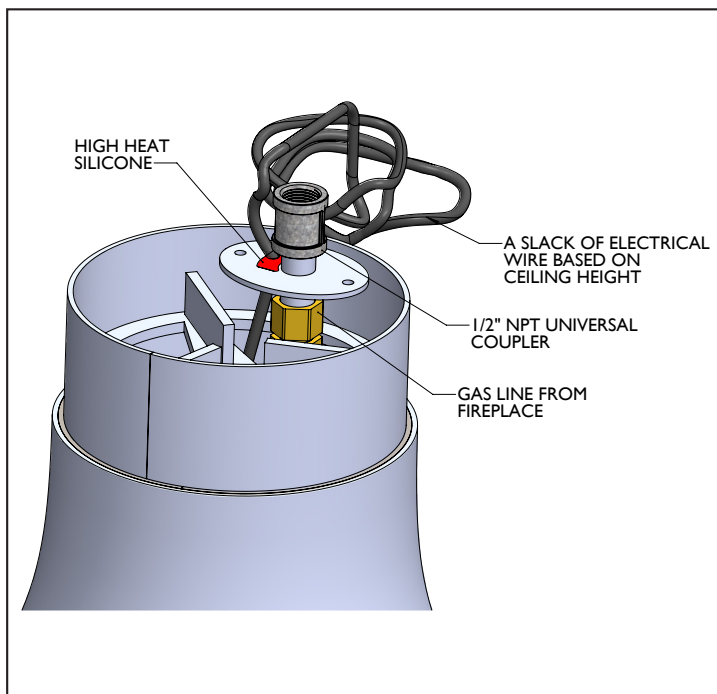

Figure.8

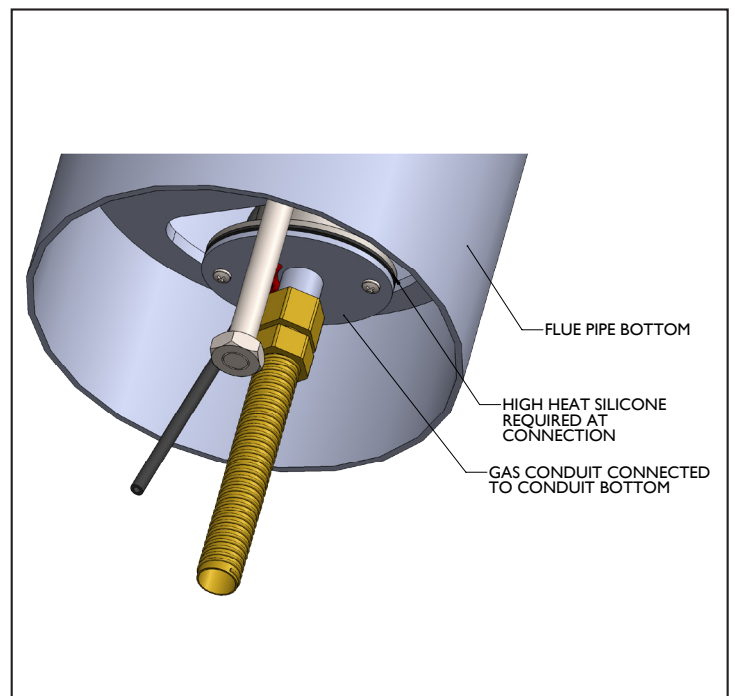



Figure.10

FIREPLACE INSTALLATION

 **NOTE:** This fireplace is equipped with an Enervex Power Vent System, there will be an additional connector to run the Enervex wires through the conduit with the gas line.

 **THE CONNECTION DETAIL:** Since this connection must be air-tight, the gas line from the burner is equipped with a special flanged nipple. There are two holes in the flange (See Figure 9).

Carefully pull the gas line up out of the body, removing the slack from the line, to make the connection. Connect the gas line from the flue to the nipple onto the gas line from the burner.

From the access door on the anchor, remove some of the slack from the gas line that was fished through the flue conduit. Make your connection(s) either to your flexible gas supply line or to the nipple on the underside of the stop disc in the anchor if your anchor is hard-piped. Turn the gas on and test all connections for leaks. All connections in the fireplace have been factory tested, but it is best practice to test all connections on-site.

Align the holes of the flange on the gas nipple from the fireplace body with the flange on the end of the flue conduit. **DO NOT** dislodge the red silicone O-ring which is adhered to the flange. Insert and tighten the fasteners provided until they are hand-tight. Remove the access door from the front of the fire bowl or the vertical heat shield inside the body. Put the cover aside for safe keeping.

Lift the fireplace body into place ensuring that the upper bearing assembly or non-rotating washer assembly is in place. As you lift the fireplace, manipulate the flex-line through the access door as required to ensure that there is slack in the line. Add the lower bearing/washer assembly and tighten as required. A safety cotter pin is now inserted into the hole.

You may now remove remaining packaging and/or foam materials. Connect any control and power supply wires required for the Enervex System. Replace the access doors on the fireplace body and the anchor.

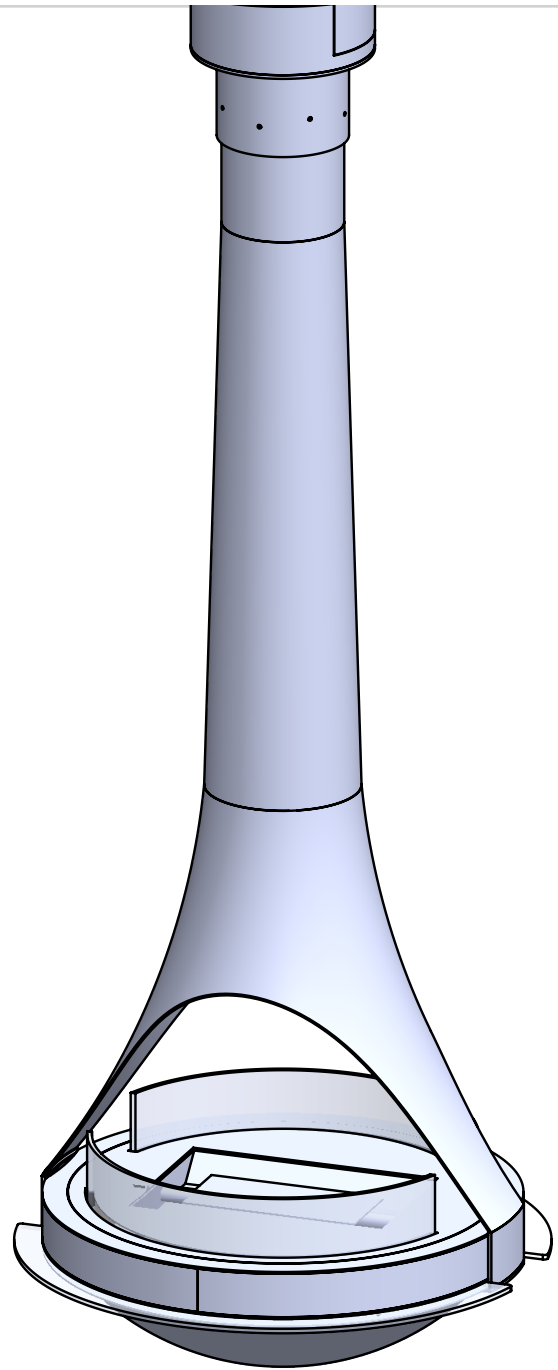

ASSEMBLY VIEW

FIREPLACE INSTALLATION

5. Connecting the conduits for multiple flue sections. (If applicable)

Note: This step is only required if you have multiple flue sections based on your ceiling height.

Fasten the Lower Conduit to the Upper Conduit pre-welded in the flue pipe before installing the multiple flue sections. The Upper Conduit has a gasket, glued to the bottom flange, which will ensure a tight seal when the lower conduit will be fastened to it. Repeat this step for as many sections of conduits supplied. Please refer to Figure 11 & 12

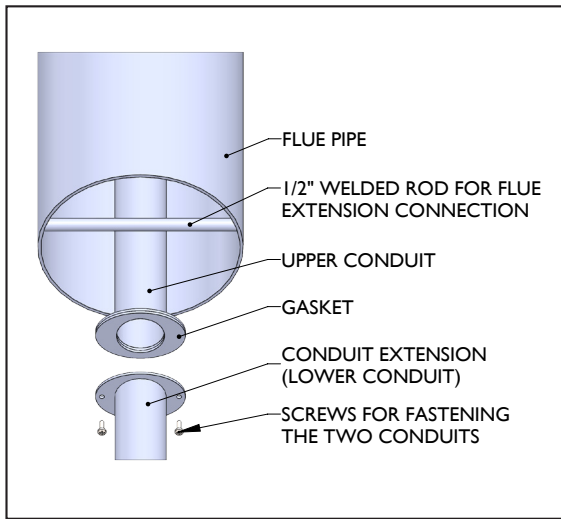

Figure. 11

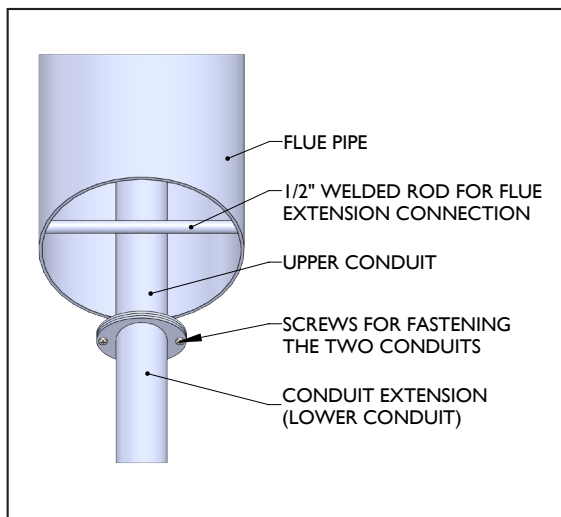

Figure. 12

6. Install the multiple flue sections. (If applicable)

Note: This step is only required if you have multiple flue sections based on your ceiling height.

A 1/2" round rod is welded into the bottom of the first flue (See Figure 13). The top of the flue pipe section has laser cut-outs to accommodate the rod in the top flue. Feed the flexible gas line down through the conduit in the flue pipes from the access door in the anchor.

You can now raise the second section of flue pipe with the male collar that has the laser cut outs in it, into the first piece of flue pipe.

Then insert the two 3/16" split pins into the holes on each side of the flue pipe to lock it in place. Both the flue pipe is now connected.

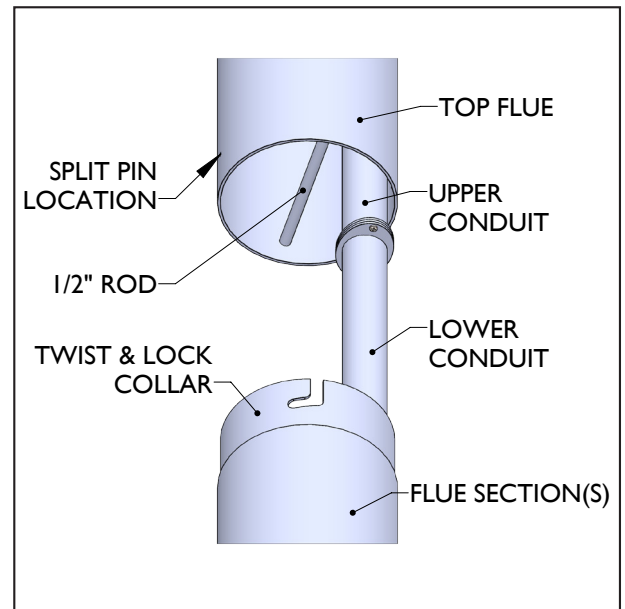

Figure. 13

Repeat this step for as many sections of flue pipe supplied.

FIREPLACE INSTALLATION

7. Install the Decorative Chimney (OPTIONAL) (VERTICAL TERMINATION)

If you have chosen to have the decorative chimney cover, please follow the instructions below to complete the installation on roof top.

The anchor assembly will have a pre-welded base for installing the decorative chimney. (See figure 14).

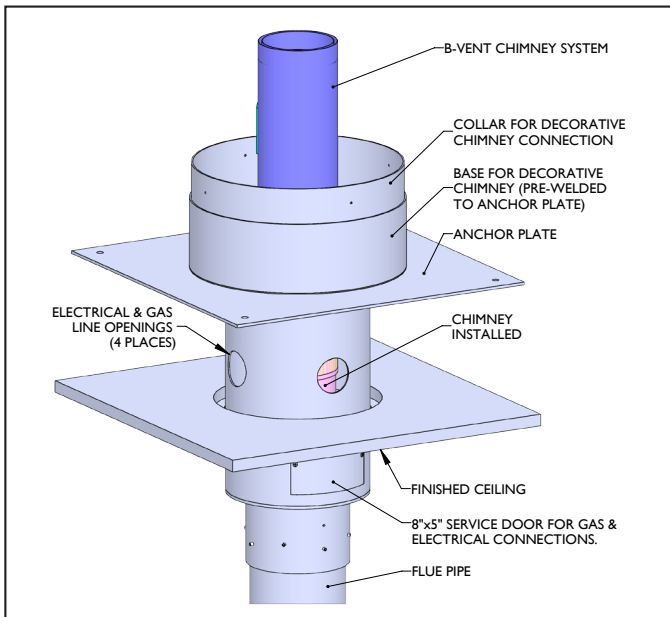

Figure. 14

Before installing the decorative chimney, install all the B-Vent components on the chimney venting installation collar. Please refer to Appendix-B, Chimney Venting Installation for detailed installation steps. **DO NOT INSTALL THE ENERVEX COMPONENTS NOW.**

Install the decorative chimney middle section with pre-welded storm collar and conduit for an electrical wire run. Bring in all the electrical wires for ENERVEX wiring before you fasten the middle section to the base. Connect the silicone/copper tube from the PDS box to the SENSOR pre-installed in the B-vent. You can now fasten the middle section of the decorative chimney and install the ENERVEX components. (Automatic Damper, Chimney Adapter & Power Exhaust Fan). Please refer to Appendix-B for more information on the ENERVEX component installation.

⚠ NOTE: APPLY HIGH HEAT SILICONE AND SEAL ALL THE GAPS BETWEEN B-VENT AND STORM COLLAR. APPLY SILICONE TO THE SEAM OF THE B-VENT ABOVE THE STORM COLLAR.

You can now cover the ENERVEX fan and Damper with the last piece of Decorative Chimney, the top section which has ventilation slots in it. (See Figure. 15 & 16)

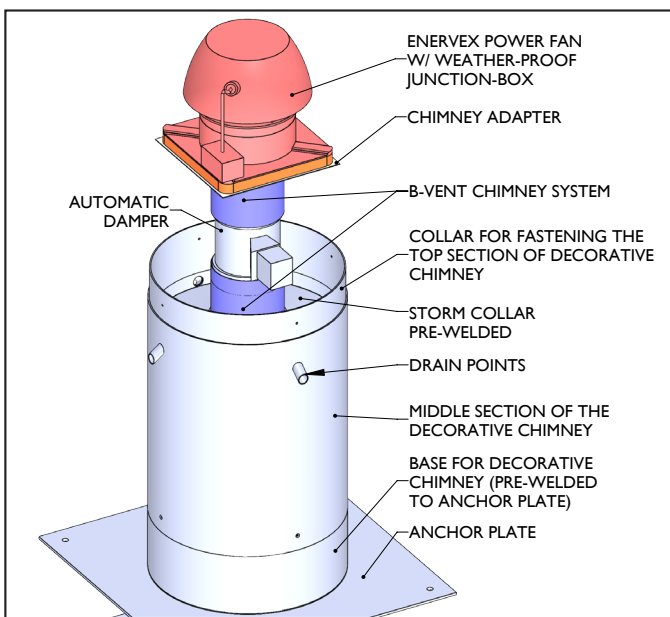

Figure. 15

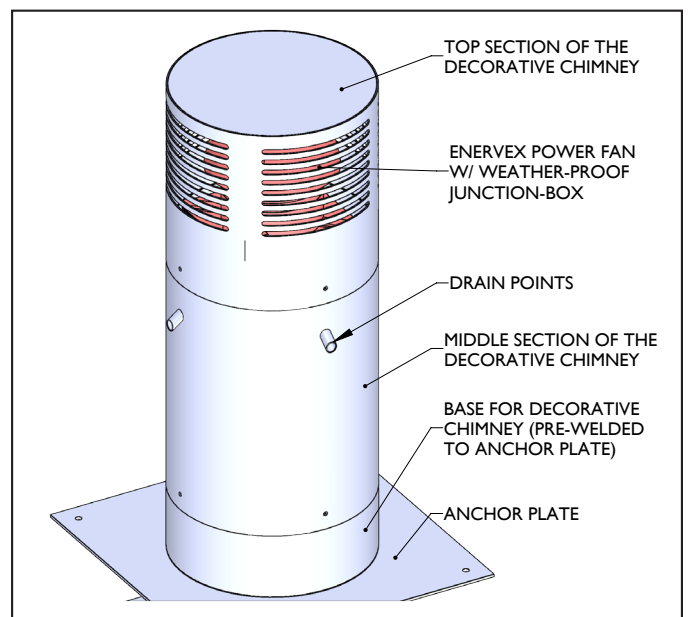

Figure. 16

FIREPLACE INSTALLATION

8. Install the Decorative Chimney (OPTIONAL) (HORIZONTAL TERMINATION)

If you have chosen to have the decorative chimney cover, please follow the instructions below to complete the installation at the wall outlet.

Ensure you have a hole in the wall to bring in the electrical for ENERVEX power exhaust fan. The connection with the damper and PDS sensor will be done from inside the wall within the ceiling structure.

Install the B-vent chimney system following the guidelines and instructions provided in Appendix-B Chimney & Venting Installation & Operation. Once the wall thimble has been installed and secured in place, you can now install the components that are numbered in the figure 17. Install all the component in the order they are numbered in the figure. 17

For connection with ENERVEX power fan please refer Appendix-B - Enervex intelli draft system instructions.

NOTE : ALL THE CONNECTIONS, SEAMS AND JOINTS OUTSIDE THE WALL SHALL BE SEALED WITH HIGH HEAT SILICONE TO PREVENT WATER ENTERING FROM OUTSIDE.

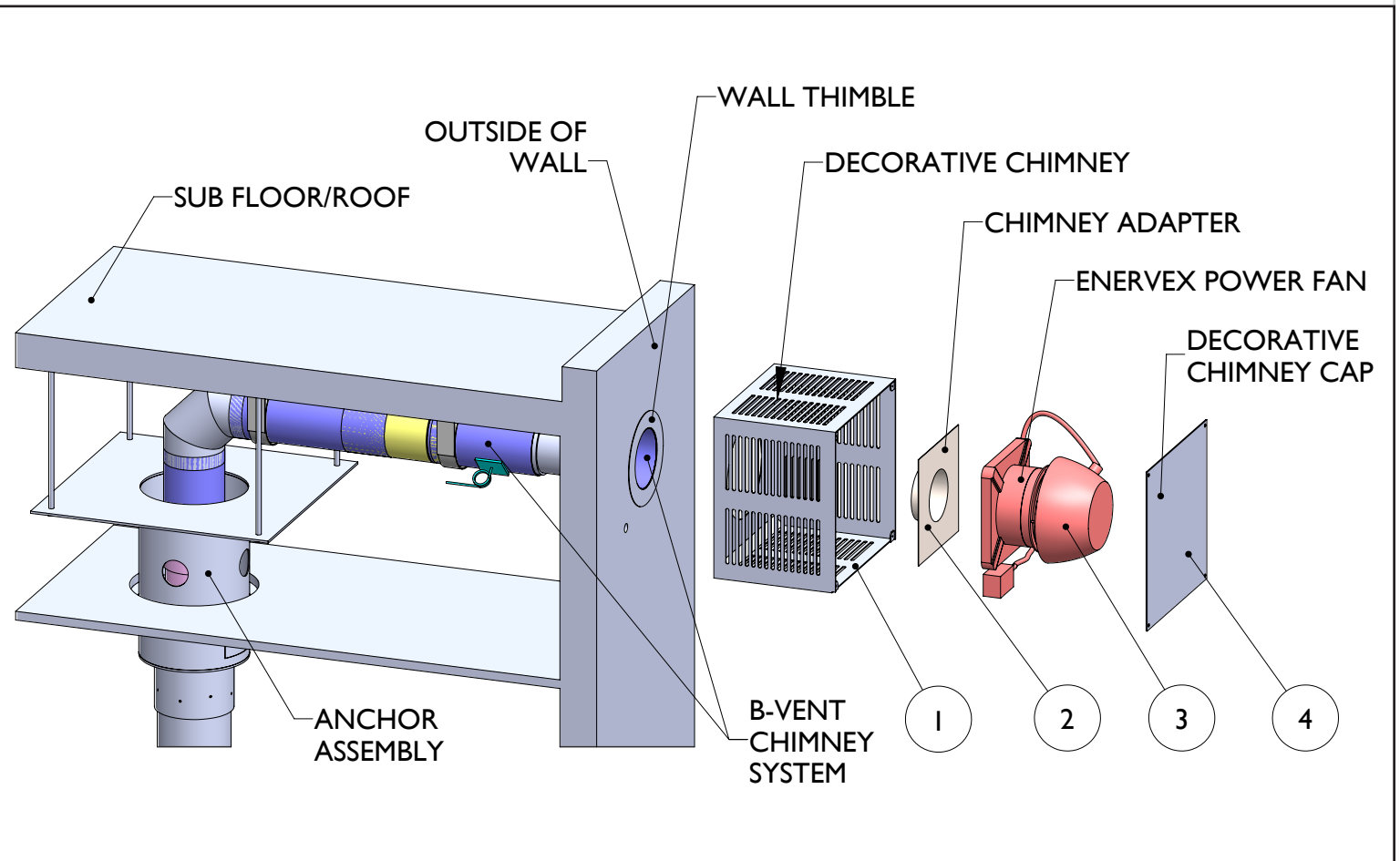

Figure. 17

APPENDIX-B

BURNER INSTALLATION | OPERATION

This fireplace is pre-assembled with the burner installed and factory set.

Follow the instructions below for completing the Gas & Electrical Connections, test firing the Burner and adding Media.

Gas & Electrical Connections:

WARNING :

A qualified installer or service person must connect the appliance to gas supply. Follow all local codes.

WARNING :

Electrical connections should only be performed by a qualified, licensed electrician. Main power must be off when connecting to main electrical power supply or performing service. All wiring shall be in compliance with all local, city, and state codes. The appliance, when installed, must be electrically grounded in accordance with local codes, or in the absence of local codes, with the National Electrical Code ANSI/ NFPA 70 (latest edition) and Canadian Electrical Code, CSA C22.1.

Gas piping system must be sized to provide minimum inlet pressure (*listed on rating plate*) at the maximum flow rate (*BTU/hr*). Undue pressure loss will occur if the pipe is too small. When using copper or flex connectors use only fittings approved for gas connections.

1. Make sure the fireplace gas supply is turned off.
2. The Gas & Electrical connections are located in the fireplace and can be accessed through the access door on the fireplace.
3. Open the fireplace access door and connect the main Gas & Electrical line to the burner.
4. The fireplace has been manufactured with a hard-piped Gas connection or Flexible Gas line.

Leak Test:

Turn on the fireplace gas supply, and test at all connections for leaks using the appropriate soapy water or approved leak testing spray or electronic sniffer. If bubbles appear, a leak is present. Turn off the gas and tighten all connections. Repeat until no leaks are present.

Check for gas leaks at the burner, field made joints/gas shut off valve, and pilot too. If a leak persists, turn off the gas supply and contact the local gas company or dealer.

WARNING :

NEVER USE AN OPEN FLAME TO CHECK FOR LEAKS. IF USING A SOAP AND WATER SOLUTION TO TEST FOR LEAKS, DO NOT SPRAY SOLUTION ONTO THE ELECTRONIC PARTS.

Make sure the flame is even along the burner and appliance is fully operational and safe for use. Turn OFF the appliance and gas supply and let it cool before adding media.

Adding Burner Media

1. Evenly fill the media compartment with burner media (sand/crushed glass) fully covering the burner. If you are **NOT** planning to add optional topping media, then fill the media compartment in full.
2. If you are planning to add some topping media (optional colored glass or lava rock), leave approximately $\frac{3}{4}$ " not filled on top of burner media.
3. Place and evenly distribute topping media (*optional colored glass or lava rock*) on top of burner media. Make sure that pilot opening is not blocked with media.
4. Place the heat shield over the controls and/or valve.

WARNING :

Important: Heat shields must be in place during operation of the gas burner system. Overheating of the valve and/or controls will cause shut down of the gas burner system or other operating problems.

WARNING :

Do not operate the fireplace without the burner being filled completely with media. Lighting the burner without the glass media will cause unsafe temperatures within the fireplace.

LIGHTING INSTRUCTIONS

Safety Information

This appliance is equipped with an ignition device which automatically lights the pilot. Do not try to light the pilot by hand.

BEFORE OPERATING smell all around the fireplace area for gas. Be sure to smell next to the floor because some gas is heavier than air and will settle on the floor.

WHAT TO DO IF YOU SMELL GAS:

- Do not try to light any appliance.
- Do not touch any electric switch; do not use any phone in your building.
- Immediately call your gas supplier from a neighbor's phone.
- Follow the gas suppliers' instructions.
- If you cannot reach your gas supplier, call the fire department.

Main gas valve in this fireplace is not serviceable and does not have any control knobs or switches to operate. Do not remove heat shields covering the valve and electronic devices; do not try to repair or modify the valve as it may result in a fire or explosion. Call a qualified service technician if you have any safety concerns.

Do not use this appliance if any part of it has been under water. Immediately call a qualified service technician to inspect the appliance and to replace any part of the control system and any gas control that has been under water.

For all valves, the air **MUST** be purged from the gas line before the pilot will light and burn properly. The time needed to purge will depend on the length of the gas line to the unit and the amount of time since the unit or gas line was last used. It may take several minutes before all the air is purged and the pilot will light and burn properly.

Operating Instructions

1. **STOP!** Read the safety information above.
2. Turn off any electrical components used with the burner system.
3. Verify that the wall switch is **OFF**.
4. Wait five (5) minutes to clear out any gas. If you smell gas, **STOP!** Follow the safety information above. If you don't smell gas, go to the next step.
5. Depress the wall switch to **ON**. This will activate the **ENERVEX Intelli Draft System** and transmits a rapid series of sparks at the pilot head located on the side of the burner. These sparks cease when the pilot flame is lit and stable. After a short time, the pilot will light the main burner.



CAUTION:

IF THE GAS SET DOES NOT IGNITE WITHIN 20 SECONDS, STOP. TURN THE WALL SWITCH OFF, WAIT FOR FIVE (5) MINUTES TO CLEAR OUT ANY GAS, THEN REPEAT STEPS 3-5 ABOVE.

The pilot should remain lit. If it goes out, repeat steps 3 through 5 above. If the pilot will not stay lit after several tries, follow the instructions "To Turn Off Gas To Appliance" below and call your service technician or gas supplier.

TO TURN OFF GAS TO APPLIANCE

1. Turn off all electric power to the appliance.
2. If required, open the access door to access manual shutoff valve on gas line.
3. Turn the gas control manual valve to the full **OFF** position.
4. The burner will extinguish, and the pilot will go out.

Due to the very gradual polymerization of the components, the unit may give off a light smoke the first few times the fire is lit. The painted surfaces nearest the fire may, while hot, acquire a certain viscosity, or slight stickiness perceptible to the touch. We advise, therefore:

- Not to be alarmed at possible smoking or residual odors. This is normal on first fires and will rapidly subside.
- Not to touch, rub or try to clean the fireplace while it is still hot.

CHIMNEY | VENTING INSTALLATION & OPERATION

A major cause of vent related fires is failure to maintain required clearances (air spaces) to combustible materials. It is of the utmost importance that Type B gas vent be installed only in accordance with these instructions.

Note: Read through all of these instructions before beginning your installation. Failure to install as described in this instruction will void the manufacturer's warranty, and may have an effect on your home-owner's insurance and UL listing status. Keep these instructions for future reference.

The placement of the vent and fittings must be in accordance with Local Codes, as well as accepted venting practices.

The Local Authority having jurisdiction should be consulted at this time. In most localities, building permits are required for any new appliances, or modifications to existing venting systems.

Clearance to Combustibles: A 1-inch clearance (air space) to combustible materials must be maintained, when using Round B-Vent, regardless of the pipe diameter.

Examine the area where the vent system will terminate. The height of the termination above the roof is determined by the roof pitch, and also its proximity to adjacent walls or obstructions. Vent pipe with 3"-12" diameter must terminate at least 2 feet higher than an adjacent wall or obstruction, if it is within 8 feet. Vent pipe with 14" or larger diameter must terminate at least 2 feet higher than an adjacent wall or obstruction, if it is within 10 feet.

Your anchor has been equipped with a stop-disc, through which the chimney vent connector protrudes. When looking down into the body of the anchor from the opening at the top, you will see this plate. This plate acts as both a heat-stop and as a rest for the bottom of the chimney system.

Steps For Typical Installation

1. Building Code requires the fireplace to be located as close to the vent as possible. After consulting the local codes, fireplace installation instructions and any other applicable reference material determine the optimum location for the fireplace.
2. Locate and mark the center of the penetration point through the ceiling or the wall.
3. For a through-the-wall system, install the Wall Thimble, as shown in Figure 2. The Wall Thimble is designed to accommodate walls up to 6 inches thick. If you have thicker walls, a sleeve extension has been fabricated and attached to the existing sleeve. Do not fill the air space between the B-vent Pipe Section and the Wall Thimble with insulation, although an RTV-type sealant may be applied around the flange and nail heads if desired.

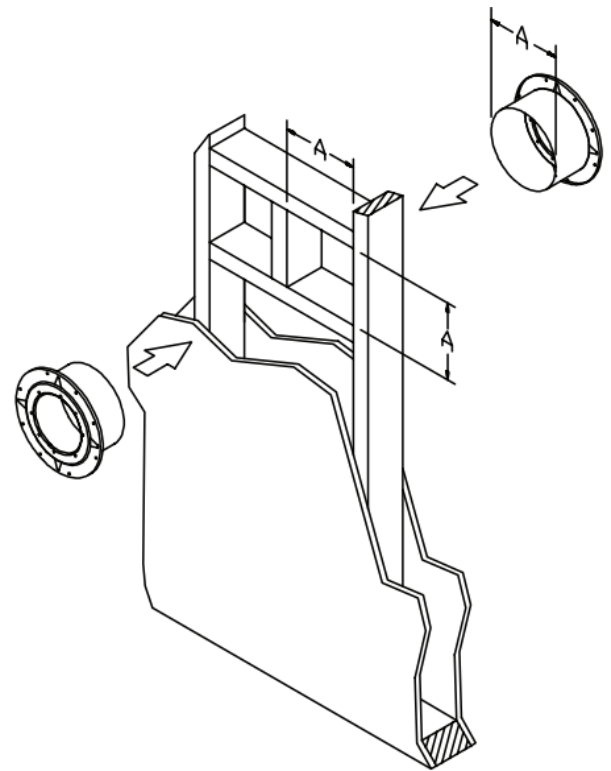

Figure 2

4. Sections of B-vent round pipe are joined together by lining up the female end of the locking lug with the male end slot, pushing them together, and turning clockwise to twist lock. Refer to Figure 9.
5. Sheet metal screws are not needed for 3" through 8" diameter pipe. However, if desired, use 1/4-inch long sheet metal screws for 3" through 8" diameter pipe. Never penetrate the inner liner with screws.

CHIMNEY | VENTING INSTALLATION & OPERATION

For 10" through 16" diameter pipe, use a minimum of (4) $\frac{3}{8}$ " sheet metal screws per joint, and a minimum of (6) $\frac{3}{8}$ " sheet metal screws are required per joint for 18" and larger diameters. Each Pipe Section is labeled, and an arrow shows the direction of the exhaust flow.

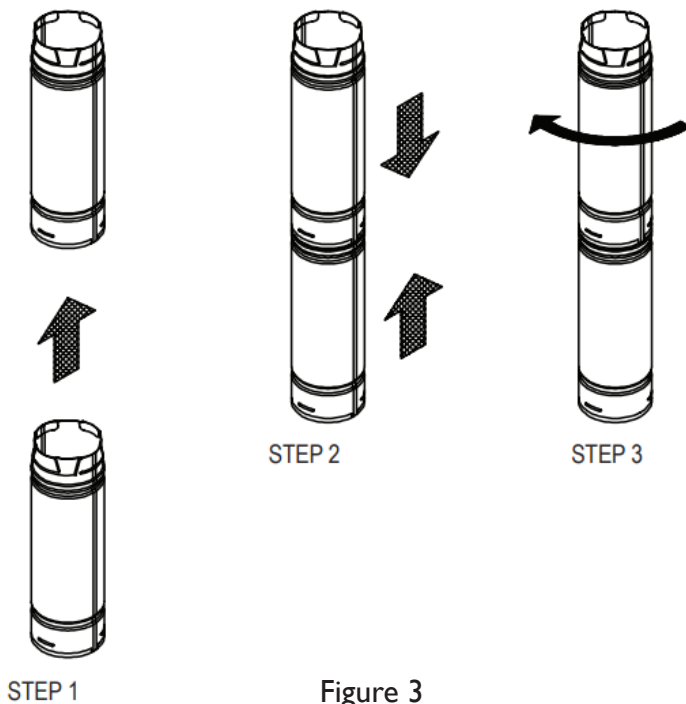

Figure 3

- Only supplied connectors should be used between the fireplace and the venting system. Some fireplaces require Type B-Vent as a complete dedicated system from the flue collar of the fireplace to the termination of the vent to the outside atmosphere. If a B-vent connector is required, UL listed double wall Draft Hood Connector can be used.
- When Elbows are required, strap the Pipe Sections and/or Elbows in place using Wall Straps. **Important: the offset must be supported with Wall Straps to prevent the weight from stressing the elbows.**
- Wall Straps should be used to support the vertical pipe as needed to provide a secure installation. Wall Straps every four feet are required.
- Any portion of the vent which passes through an occupied area must be enclosed, to prevent accidental damage to the system, as well as burns. Figure 1 shows a system which passes through an occupied second floor. Consult the Local Authority prior to construction. Note that the enclosure requires an access door for inspection and maintenance purposes.

10. Where the Pipe Sections pass through the roof, a hole must be cut to provide a minimum clearance (*air space*) of 1 inch between the Pipe and construction materials. A Roof Flashing is placed down over the pipe, and adjusted so it fits tightly against the roof, with the Pipe Section held in a position maintaining the 1 inch minimum clearance from combustibles. The Flashing is then nailed to the roof. The roofing material (*shingles, asphalt paper, etc.*) should overlap the top edge (*uphill side*) of the Flashing.

11. A non-hardening sealant should be used around the edges of the flashing base where it meets the roof. Non-hardening sealant is placed around the joint between the Flashing and the vertical Pipe Section. The Storm Collar is then placed over this joint, to make a watertight seal. (Figure 4)

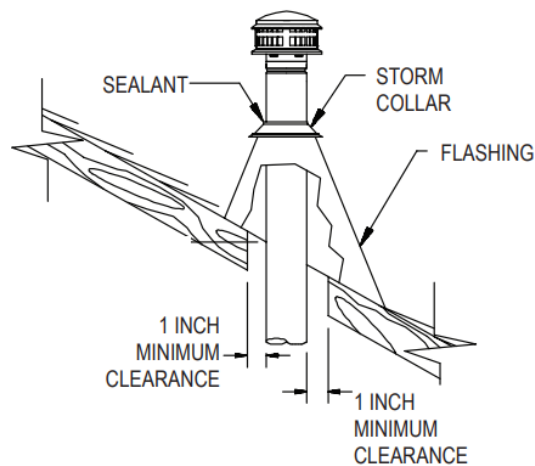

Figure 4

12. Conduct a final inspection to ensure that all joints are secure, the system is properly supported, and is mechanically sound. Especially verify that the one-inch clearance to combustibles requirement has been met, and that adequate combustion air will be furnished to the fireplace.

CHIMNEY | VENTING INSTALLATION & OPERATION

Adjustable Elbows

1. This section furnishes supplemental information concerning Adjustable Elbows, both 90° and 45°/60°.
2. In addition to twist locking the elbows, the connection may be further secured by using sheet metal screws at the joint where the male and female parts overlap, provided that the screws **DO NOT** penetrate the inner liner. One screw per joint is normally sufficient. Use #8 Pan Head sheet metal screws which are no longer than ¼ inch.
3. Wall Straps must be used to support each elbow. Do not allow the elbows to support the weight of the vent pipe.
4. The installer should apply pressure to the section at the points indicated by the arrows. This will prevent the adjacent sections of the elbow from turning, as the next pipe or fitting is twist-locked on. This is important, because once these sections start rotating, the elbow does no longer have a 90° angle. The Elbow is completely adjustable from 0° to 90°. Note: The centers of the upper sections tend to displace by a slight amount, as they are rotated. Again, screws (*not longer than ¼"*) may be used to secure the joint. Wall Straps should also be utilized to enhance the stability of the vent system.

ENERVEX INTELLI DRAFT SYSTEM

(OVERVIEW):

The Intelli Draft connects a draft and safety controller, the ADC100 and its pressure sensor, to an RS chimney fan, the MFD chimney damper and the fireplace's gas valve. When the user wants to turn on the fireplace (typically using a wall switch) the controller signals the mechanical chimney damper to open.

When the damper is open, the controller automatically ramps up the chimney fan speed until the draft set-point has been reached and the integrated draft protection switch closes.

At this point, the controller allows the fireplace to fire by opening the gas valve. During operation of the fireplace the control continues to monitor the draft and will maintain the proper draft set-point by modulating the chimney fan speed whenever needed.

When the user turns the fireplace or appliance off, the control leaves the damper open until all residual combustion products have been exhausted out of the building by the chimney fan; then the control discontinues chimney fan operation and closes the damper.

If for any reason the draft set-point can't be maintained during operation, the controller will completely shut down the fireplace or appliance operation.

Intelli Draft creates the safest operation for any gas-fired fireplace or decorative appliance and exceeds even the building codes' strictest safety requirements.

- Protects against downdrafts.
- Eliminates spillage and CO release due to building depressurization.
- Automatically shuts down fireplace operation, if conditions are unsafe.

Your chimney system has been supplied with an Enervex Power Vent System which must be installed in accordance with the manufacturer's instructions. Refer to ENERVEX component's installation Manual for more information and instructions on installation & maintenance.

CLEANING AND MAINTENANCE



WARNING:

Turn off gas before servicing fireplace. It is recommended that a qualified service technician perform these check-ups at the beginning of each heating season.

Once installed and operating properly, your fireplace will require regular maintenance. Burning the supplied media for any length of time will cause the fireplace to soot. Soot is caused because of incomplete combustion of the gas leaving behind a dark dense material. Soot will also accumulate, if the media is not placed in the properly. To clean off soot use an old tooth brush and gently rub away the soot where applicable.

The realistic flame produces carbon monoxide and soot. Under standard conditions these byproducts are exhausted up the chimney. IF the fumes or soot from the burning gas are evident in the room when the damper is fully open it indicates that the fireplace draft is defective. IF this happens **DO NOT** operate your fireplace until the fireplace draft is corrected, call a service technician to fix the problem.

Burner, Pilot And Control Compartment

Keep the control compartment clean by vacuuming or brushing at least twice a year or depending on your usage. Make sure the burner porting, pilot air opening and burner air openings are free of obstructions at all times. Inspect area around the burner. Remove any lint or foreign material with a brush or vacuum. Clean and readjust the burner air shutter. Clean and test the igniter and pilot (*if equipped*).

Pilot Flame

The flames from the pilot should be visually checked as soon as the unit is installed and periodically during normal operation. The pilot flame must always be present when the fireplace is in operation or connected to the gas line with main shutoff valve open and the IPS activated (*powered*). The pilot flame has two distinct flames, one engulfing the flame sensor and the other reaching to the main burner.

Flame Description

Observe the flames. the flames should be blue at the base and a combination of blue/yellow at the body and tips. Inspect the flames periodically. If the flames appear different, contact a professional service technician or your gas supplier to correct the problem.

More frequent cleaning and maintenance may be necessary when burning propane gas than with natural gas. It is recommended to perform service and maintenance at the beginning of each fireplace season and as needed throughout the year, depending on your usage pattern and the environmental conditions in your home.

Before lighting your first fire it is necessary to clean off (*with a damp sponge and/or a dry cloth*) any dirt collected during transport or installation.

Actual scratches in the paint can be retouched solely with the touch-up paint provided. If this is necessary, ventilate the area thoroughly before lighting your fire to disperse any fumes generated in the spraying process.

The outer surfaces can be wiped with a soft, dry cloth (*making sure the metal is cool*). For continued use of the touch-up paint can (*following its initial usage*), invert the can (*spray nozzle down*) and spray into a balled-up newspaper until the can sprays clear. Clean the spray can bottom with a dry rag and store out of the reach of children.

Chimney Venting System

Have the venting system of the fireplace inspected and cleaned annually by a qualified agency.

An annual inspection is required to maintain warranty of your B-Vent system. You will need to inspect the Vent Pipe, Connector Pipe, and the connection to the fireplace.

Verify that the sealant around the Flashing and Storm Collar is intact. Reseal as needed.

CLEANING AND MAINTENANCE (CONTINUED)

Inspect vent for any physical damage or damage from corrosion. Look for any foreign material inside the vent. (*Example: bird's nest, leaves, etc.*)

Shine a light down inside of the vent pipe. Look for any evidence of damage, corrosion or excessive condensation. Also, look for any disconnected sections of the vent pipe or connector pipe. Refer to the installation instructions to reconnect pipe sections. If pipe sections are damaged or corroded, replace immediately!

Inspect fireplace connector and make sure that the vent is securely connected to the fireplace.

Damaged or corroded parts should be replaced immediately! Failure to do so can lead to an extremely hazardous situation!

Follow your manufacturer's recommended instructions for inspection your fireplace.

REPLACEMENTS

CAUTION : DO NOT USE SUBSTITUTE MATERIAL!

For ordering replacement parts, please contact CF + D | custom fireplace design.

CLOSING

If there are any questions regarding any aspect of the work to be undertaken, please contact your Technical Representative at CF+D for assistance. We thank you for your support and your business!

WARRANTY

CF + D | custom fireplace design
Quality Creativity Innovation

All Fireplace models are guaranteed against any defect in design, construction, or manufacture, and guaranteed to function properly for five (5) years from date of receipt of goods. The electrical and electronic components within the fireplace are warranted against any defect in design, construction, or manufacture, and guaranteed to function properly for one (1) year from date of commissioning. Our product guarantees are applicable only when our Fire Features have been installed with respect to all local building codes and with strict attention to the technical details outlined in our Plan Study as well as our installation, maintenance, and user's manuals. Our guarantee excludes accidental damages such as those occurring during transport without written notification upon receipt, damages incurred during installation, and damages resulting from improper use and is limited to the replacement of the defective part or unit in its entirety at the sole discretion of CF + D the manufacturer. This warranty does not include the reimbursement of labor cost or related costs incurred to conduct the replacement of parts or entire unit should it be deemed necessary.

We thank you for your support and your business!

North American Designed and Manufactured by:

CF + D | Custom Fireplace Design Inc.
5230 Harvester Rd. #2
Burlington, Ontario L7L 4X4
T: 905-681-3070
Toll Free: 1-866-909-3070
F: 905-681-8697

www.customfireplacedesign.com

CF + D | custom fireplace design

5230 Harvester Rd. Unit #2
Burlington, Ontario Canada L7L 4X4
t. 1-866-909-3070 t. 905-681-3070
www.customfireplacedesign.com

ENERVEX ADC100 DRAFT CONTROL

3916067 05.17

Installation & Operating Manual

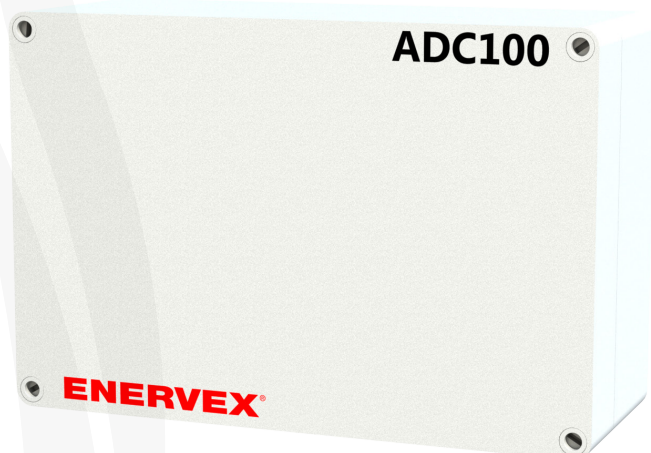

READ AND SAVE THESE INSTRUCTIONS!



Intertek

ENERVEX Inc.
1685 Bluegrass Lakes
Parkway
Alpharetta, GA 30004
USA

P: 770.587.3238
F: 770.587.4731
T: 800.255.2923
info@enervex.com
www.enervex.com

ENERVEX® 
VENTING DESIGN SOLUTIONS



The ADC100 Fan Control is ETL Listed in the U.S. and Canada: under UL 508 Standard for Industrial Control Equipment (17th Ed.) and CSA C22.2 No. 14-05- Standard for Industrial Control Equipment.

IMPORTANT: READ THESE INSTRUCTIONS CAREFULLY PRIOR TO INSTALLATION.

- **EXAMINE ALL COMPONENTS FOR POSSIBLE SHIPPING DAMAGE PRIOR TO INSTALLATION.**
- **DIFFERENT MANUFACTURERS HAVE DIFFERENT JOINT SYSTEMS AND ADHESIVES. DO NOT MIX PIPE, FITTINGS, OR JOINING METHODS FROM DIFFERENT MANUFACTURERS.**

Symbol Legend

The following terms are used throughout this manual to bring attention to the presence of potential hazards, or to important information concerning the product.



DANGER: Indicates an imminent hazardous situation which, if not avoided, will result in death, serious injury or substantial property damage.



WARNING: Indicates an imminent hazardous situation which, if not avoided, may result in personal injury or property damage.

How to use this manual

This installation manual does not contain any system design documentation. System design documentation is available from any authorized ENERVEX representative. Accessories, fans, and variable frequency drives are not covered by this manual. Please refer to these component's individual manuals.

TO REDUCE THE RISK OF FIRE, ELECTRICAL SHOCK OR INJURY TO PERSONS, OBSERVE THE FOLLOWING:

1. Use this unit in the manner intended by the manufacturer. If you have questions, contact the manufacturer at the address or telephone number listed on the front of the manual.
2. Before servicing or cleaning the unit, switch off at service panel and lock service panel to prevent power from being switched on accidentally.
3. Installation work and electrical wiring must be done by a qualified person(s) in accordance with applicable codes and standards.
4. Follow the appliance manufacturer's guidelines and safety standards such as those published by the National Fire Protection Association (NFPA), and the American Society for Heating, Refrigeration and Air Conditioning Engineers (ASHRAE), and the local code authorities.
5. This unit must be grounded.

Content

1. PRODUCT INFORMATION

1.1 Function.....	4
1.2 Shipping	4
1.3 Warranty	4

2. SPECIFICATIONS AND DIMENSIONS

2.1 Dimensions and Capacities.....	5
------------------------------------	---

3. MECHANICAL INSTALLATION

3.1 Location.....	6
3.2 Mounting the Control Unit	6
3.3 Connection of the Proven Draft Switch.....	6
3.4 Installation of the Chimney Probe.....	7
3.5 Adjusting the Fan Speed and Post Purge Time	7

4. ELECTRICAL INSTALLATION

4.1 General.....	8
4.2 Connection Diagram	9
4.3 Wiring of a Gas Fireplace	10
4.4 Wiring of a Gas Fireplace With a Damper	11
4.5 Wiring of 3-Phase Fan.....	12

5. STARTUP AND CONFIGURATION

5.1 General.....	13
5.2 Sequence of Operation	14
5.3 Operating Pressure	15

6. MAINTENANCE AND TROUBLESHOOTING

1. PRODUCT INFORMATION

1.1 FUNCTION

The ENERVEX ADC100 Draft Control is a fan speed and appliance control used to control draft for a gas appliance such as a fireplace, stove or furnace. It may be interlocked with the appliance and is for use in systems where modulation is not required. It controls the speed of a fan to maintain proper draft and pressure in a chimney system. The ADC100 is for use with ENERVEX model RS or GSV fans and is a component in the residential EcoDamper.

The ADC100 control comes with the PDS1.

The PDS is a required safety function used to ensure a negative pressure is maintained in the chimney. It also prevents appliance operation during an electrical or mechanical failure in the system.

The ADC100 can operate the chimney fan in manual or automatic mode. Manual mode allows the user to adjust the speed of the fan at any time using the potentiometer on the board. In Automatic Mode, the ADC100 will ignore the potentiometer and ramp the fan up until the PDS closes. If the PDS opens, the control will ramp up the fan until there is enough draft to re-close the switch.

The ADC100 can be interlocked with up to two appliances. Connections are made at the Auxiliary In and Auxiliary Out terminals. A 24VDC out connection is available. When an appliance is interlocked to the control, a post-purge function becomes available. The post purge keeps the fan running for a set time after the last appliance shuts down to evacuate any remaining flue gases. The post purge time on the ADC100 is adjustable from 0-3 minutes via a potentiometer on the control board.

The damper relay allows a damper actuator to be interlocked directly to the control. The control ensures that the damper is open before releasing the appliance for operation. If at any point the control has sensed total failure, the ADC100 will go into an alarm for 30 seconds and will attempt a retry. In the event of a mechanical or electrical failure, the damper fails to the closed position.

The housing is NEMA 1 rated ABS plastic.

System installation must conform to the requirements of the authority having jurisdiction. When required by the authority having jurisdiction, the installation must also conform to the NFPA31, NFPA54 or NFPA211.

All electrical wiring must be in accordance with the requirements of the authority having jurisdiction or, in absence of such requirements, with the National Electric Code, NFPA 70.

1.2 SHIPPING

ADC100 includes the control unit, PDS1, stack probe and silicone tubing.

* If other components are shipped, they will appear as separate items on the packing list.

1.3 WARRANTY

2-Year Factory Warranty. Complete warranty conditions are available from ENERVEX, Inc.

2. SPECIFICATIONS

2.1 DIMENSIONS AND CAPACITIES

ADC100 Control		
Power supply	V	1x120VAC
Amperage	A	7.0
Operating temperature	°F/°C	-4 to 122 / -20 to 50
Control signal	mA	max. 10
Control relay		Max. 120 VAC / 8A
Output	VAC	10-120
	VDC	0-10
Post Purge Time		0-3 Minutes
Alarm Delay Time		15 Seconds
Dimensions	A in/mm	9.6 / 244
	B in/mm	6.3 / 160
	C in/mm	3.5 / 90
Weight	lbs/kg	2.6 / 1.2
Chimney Probe		
Dimensions	D in/mm	4.25 / 108
	E in/mm	3.50 / 89

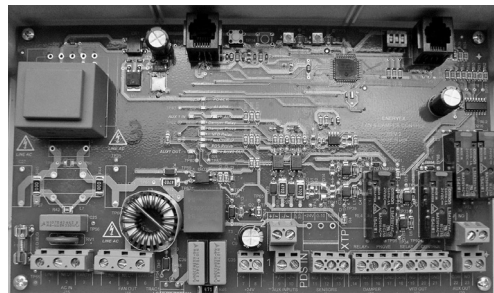
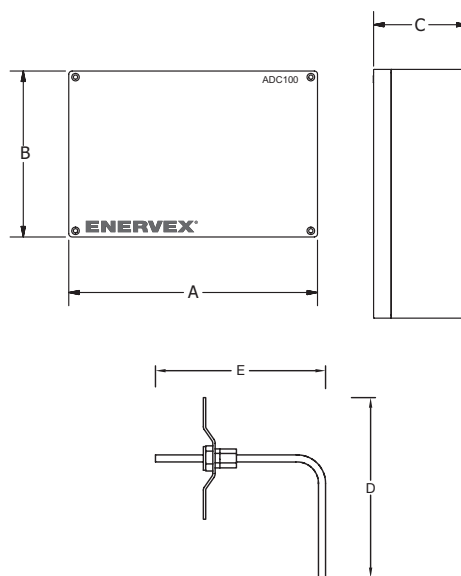

ADC100

3. MECHANICAL INSTALLATION

3.1 LOCATION

The ADC100 Control Unit must be installed indoors. As shown in Fig. 1, the control will be wired directly to a 120/1/60 VAC power supply. The control will also be connected to the fan, appliance and damper (if used). For detailed wiring information, see Chapter 4.

3.2 MOUNTING THE CONTROL UNIT

The ADC100 control may be mounted directly to a wall. To mount, remove the cover and locate the (4) mounting holes. Using the hole-pattern shown below, mount the control using #6 screws. See Fig. 2, Once it is attached, wire the unit in accordance with Chapter 4.

3.3 CONNECTION OF THE PROVEN DRAFT SWITCH AND STACK PROBE

The Proven Draft Switch (PDS) must be installed indoors, in the vertical position (pre-drilled knockouts face down). Mount the control upright to a wall or other flat surface. DO NOT lay the control down or mount horizontally.

A Proven Draft Switch (PDS) must be used with the ADC100 control as a system safety device. The PDS monitors the pressure inside the stack and signals the control to shut down the appliance if insufficient draft exists. A stack probe senses the pressure read by the PDS and is connected via silicone tubing.

The silicone tubing supplied with the PDS should be connected to the NEGATIVE (-) port of the PDS. This is the bottom port on the switch. See Fig. 3. The standard tube length is 6 feet. The distance can be extended up to 25 feet by using 1/4" rigid plastic or copper tubing as temperature allows (not supplied).

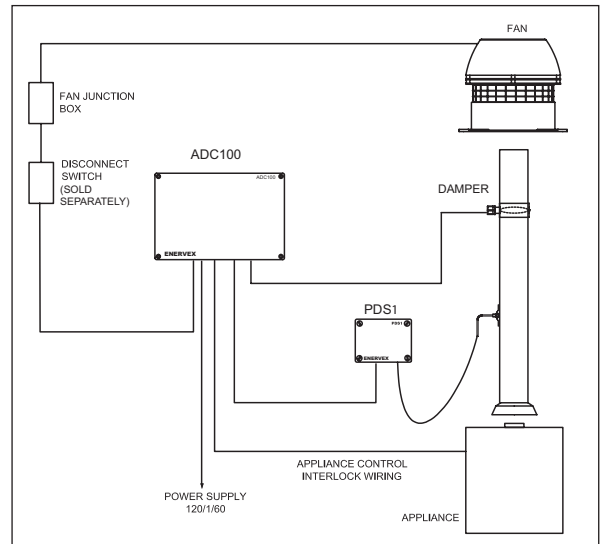

Fig. 1

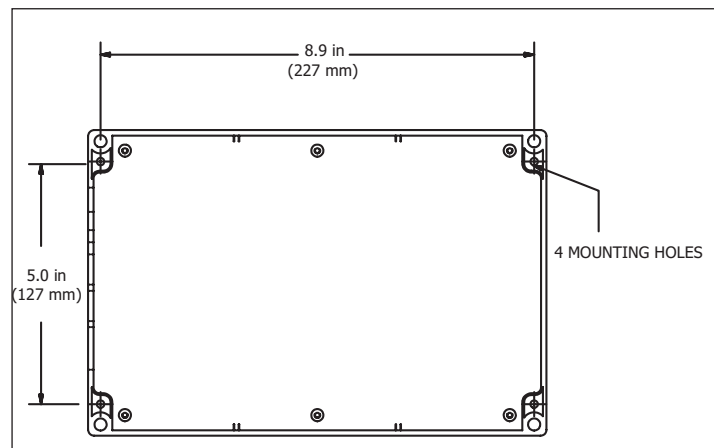

Fig. 2

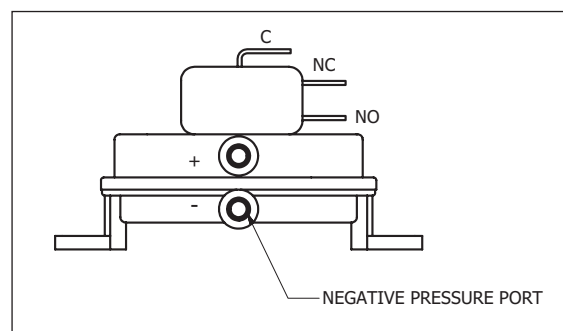

Fig. 3

3.4 INSTALLATION OF THE CHIMNEY PROBE

The probe must be installed between the appliance and the exhaust fan. If a damper is used in the system, the probe should be installed between the appliance and damper.

Locate the probe at least a distance three (3) vent diameters away from any elbow, tee or damper. For fireplace installations, the probe should be installed close to the fan inlet. See Fig. 4.

To produce an accurate pressure reading, the probe should be installed flush with the inner wall of the chimney or stack. If double walled stack is used, the probe should be flush with the inner most wall.

3.5 ADJUSTING THE FAN SPEED AND POST PURGE TIME

There are two potentiometers located on the main control board of the ADC100. To increase the fan speed, rotate the potentiometer labeled Fan Spd clockwise. Alternately, rotating the potentiometer counterclockwise will decrease the fan speed. In Manual mode, the potentiometer can be adjusted at any time during normal operation to increase or decrease the fan speed. When the control is in Automatic mode, the potentiometer is only used to set the initial speed of the fan. After that, the control will automatically adjust the fan speed to ensure the PDS stays closed during appliance operation.

A second potentiometer, labeled PG Time, is located on the top right corner of the control board. The post purge time is adjustable from 0 (no post purge) to 3 minutes. Turning the knob clockwise increases the post purge time while turning it counter-clockwise decreases the time.

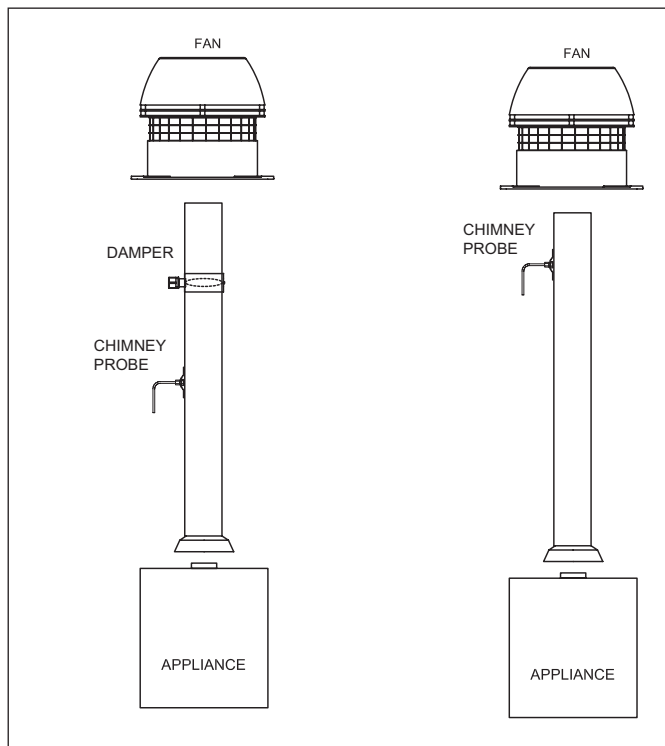
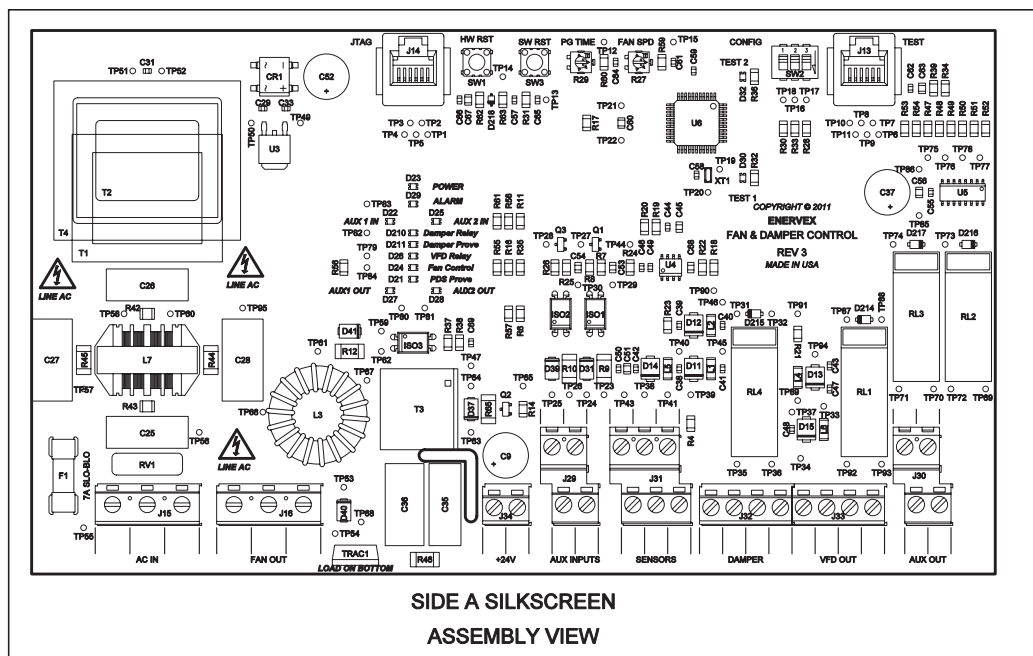

Fig. 4



SIDE A SILKSCREEN
ASSEMBLY VIEW

Fig. 5

4. ELECTRICAL INSTALLATION

4.1 GENERAL



DANGER
Turn off electrical power before servicing.
Contact with live electric components can cause shock or death.



ADC100 is designed for 1x120VAC power supply only.

The designations for each terminal on the control board are shown below. Note that some installations may not require the use of all terminals. Also shown in this section is a general connection diagram for an ADC100 control system.

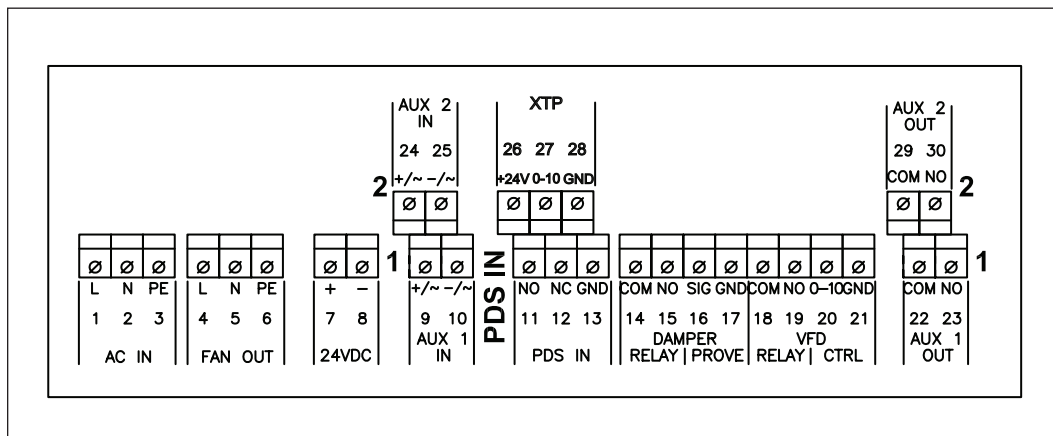

Fig. 6

Terminal	Use	Terminal	Use
1	Power Supply - L1	14-15	Damper Relay
2	Power Supply - N	16-17	Damper Prove
3	Power Supply - Ground	18-19	VFD Relay
4	Chimney Fan- L1	20	0-10 VDC Output
5	Chimney/Exhaust Fan - N (regulating)	21	0 VDC Output (Gnd)
6	Chimney/Exhaust Fan- Ground	22-23	Auxiliary Appliance Output 1 (Max Amperage 250 VAC 8 A)
7	+ 24 VDC Out	24-25	Auxiliary Appliance Input 2 (10-240 VAC or 5-30 VDC)
8	Ground (-24 VDC) Out	26	XTP- +24 VDC Out - Not Applicable
9-10	Auxiliary Appliance Input 1 (10-240 VAC or 5-30 VDC)	27	XTP In (0-10 VDC) - Not Applicable
11	PDS- Normally Open	28	XTP In (0 VDC) - Not Applicable
12	PDS- Normally Closed		Max Amperage 250 VAC 8 A)
13	PDS- Common		

4.2 CONNECTION DIAGRAM

The connection diagram shown in Fig. 7 below shows typical connections for a single phase fan. If a 3-phase fan is used, a VFD must be connected between the fan and control.

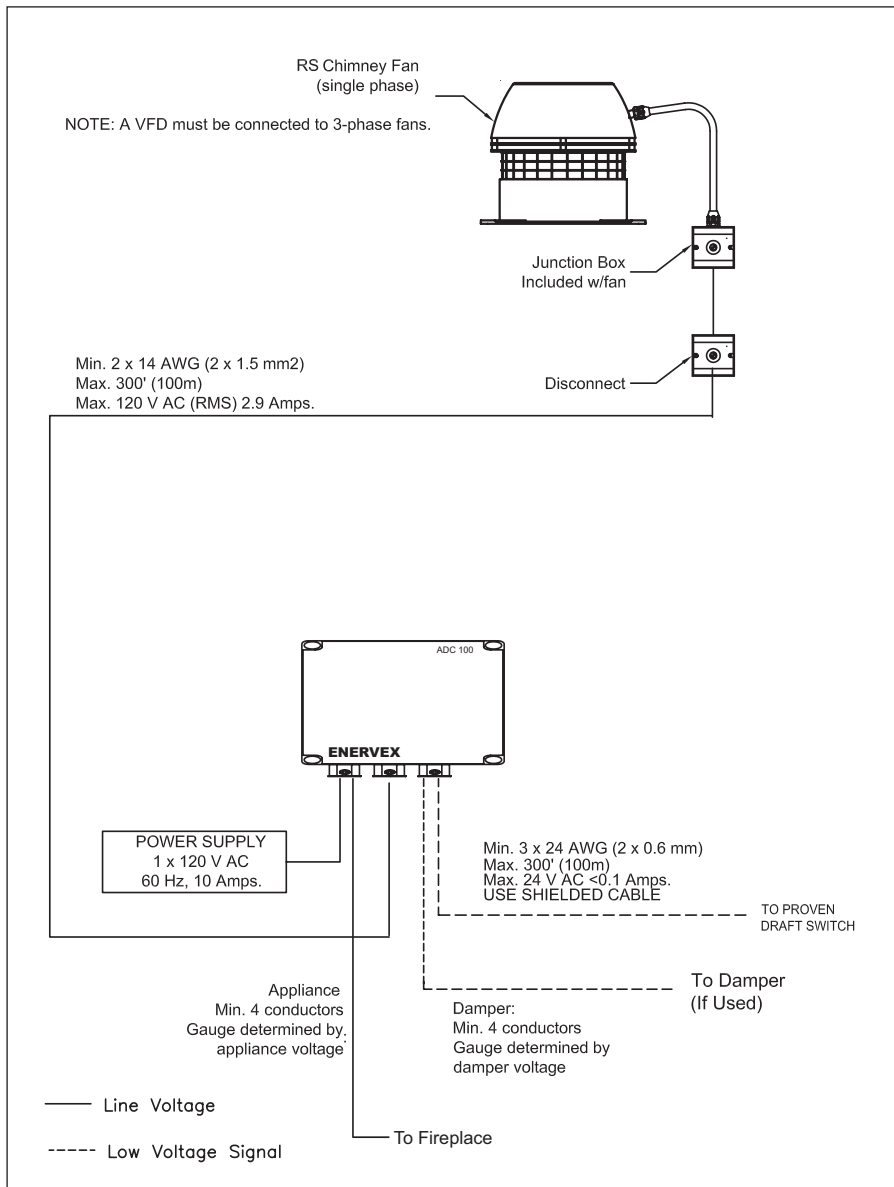

Fig. 7

4.3 WIRING OF A GAS FIREPLACE

To interlock the ADC100 with a gas fireplace as shown in Fig. 8, connect the Auxiliary In terminals 9 and 10 on the control board to a wall switch. Either by using line voltage or use board voltage from terminals 7 and 8 as depicted in figure 8. Connect the gas valve or ignition to Auxiliary Out at terminals 22 and 23. The Auxiliary Out is a normally open dry contact that closes when the PDS closes and releases the fireplace for operation. The Auxiliary In terminals are rated for maximum 250/125 VAC/VDC. Place a jumper between terminals 16 and 17 if the damper is not used.

NOTE: See Fig. 10 in Section 4.5 for connection of 3-phase fan with VFD.

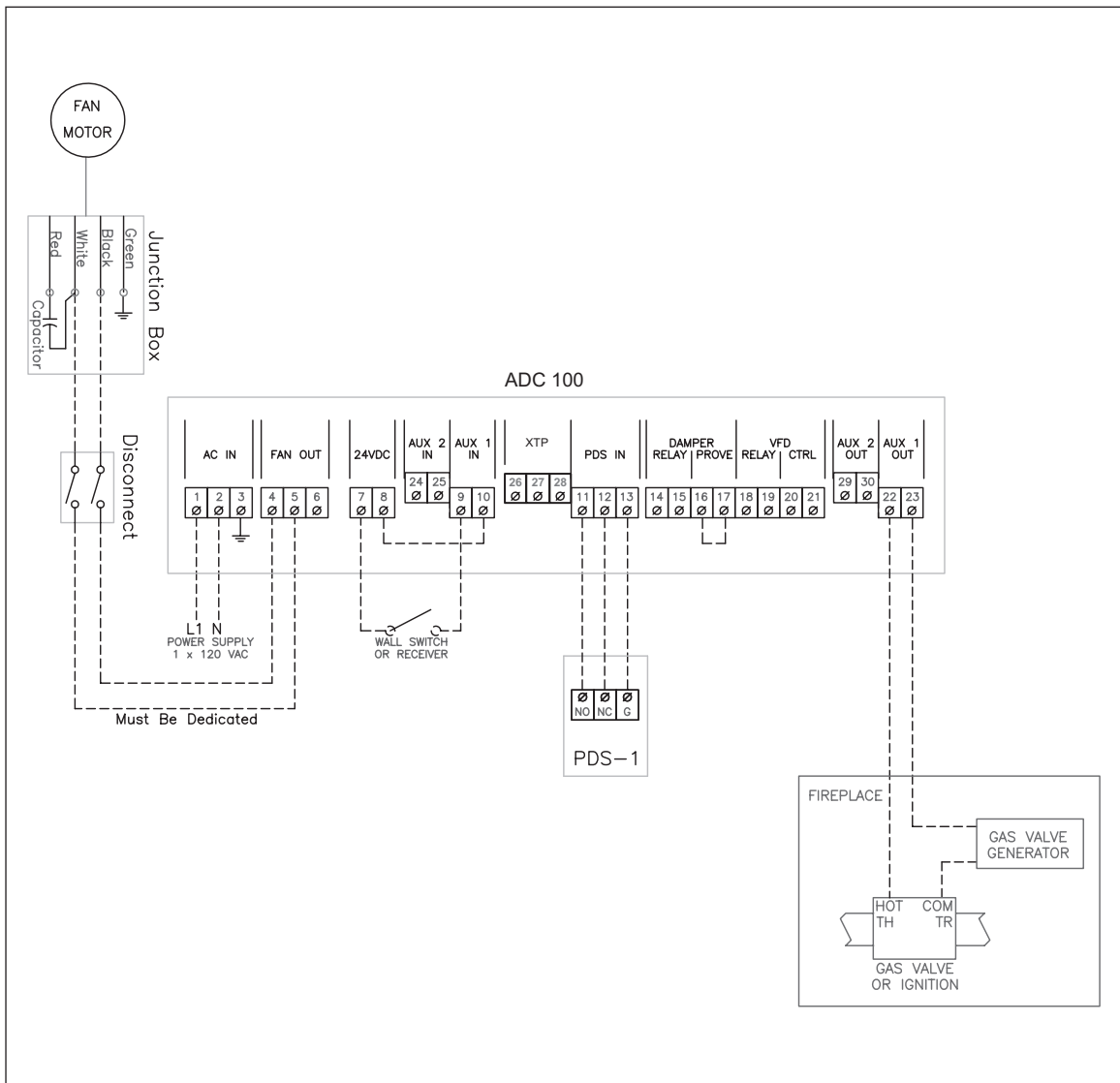

Fig. 8

4.4 WIRING OF A GAS FIREPLACE WITH A DAMPER

To interlock the ADC100 with a gas fireplace as shown in Fig. 9, connect the Auxiliary In terminals 9 and 10 on the control board to a wall switch. Either by using line voltage or use board voltage from terminals 7 and 8 as depicted in Fig. 8. Connect the gas valve or ignition to Auxiliary Out at terminals 22 and 23. The Auxiliary Out is a normally open dry contact that closes when the PDS closes and releases the fireplace for operation. The Auxiliary In terminals are rated for maximum 250/125 VAC/VDC.

NOTE: IF AN ELECTRONIC IGNITION CONTROL IS USED WITH THE FIREPLACE, DO NOT INTERLOCK IT WITH DAMPER ACTUATOR. DAMPER ACTUATOR SHOULD INTERLOCK WITH THE ADC100 CONTROL ONLY.

To interlock the damper to the control, connect the actuator to terminals 14 and 15 as shown in Fig. 9. The actuator must include an endswitch to enable the damper prove function. The damper prove function is a dry contact that closes when the damper proves open. Connect the Common and Normally Open terminals of the actuator endswitch to terminals 16 and 17 on the board.

NOTE: See Fig. 10 in Section 4.5 for connection of 3-phase fan with VFD.

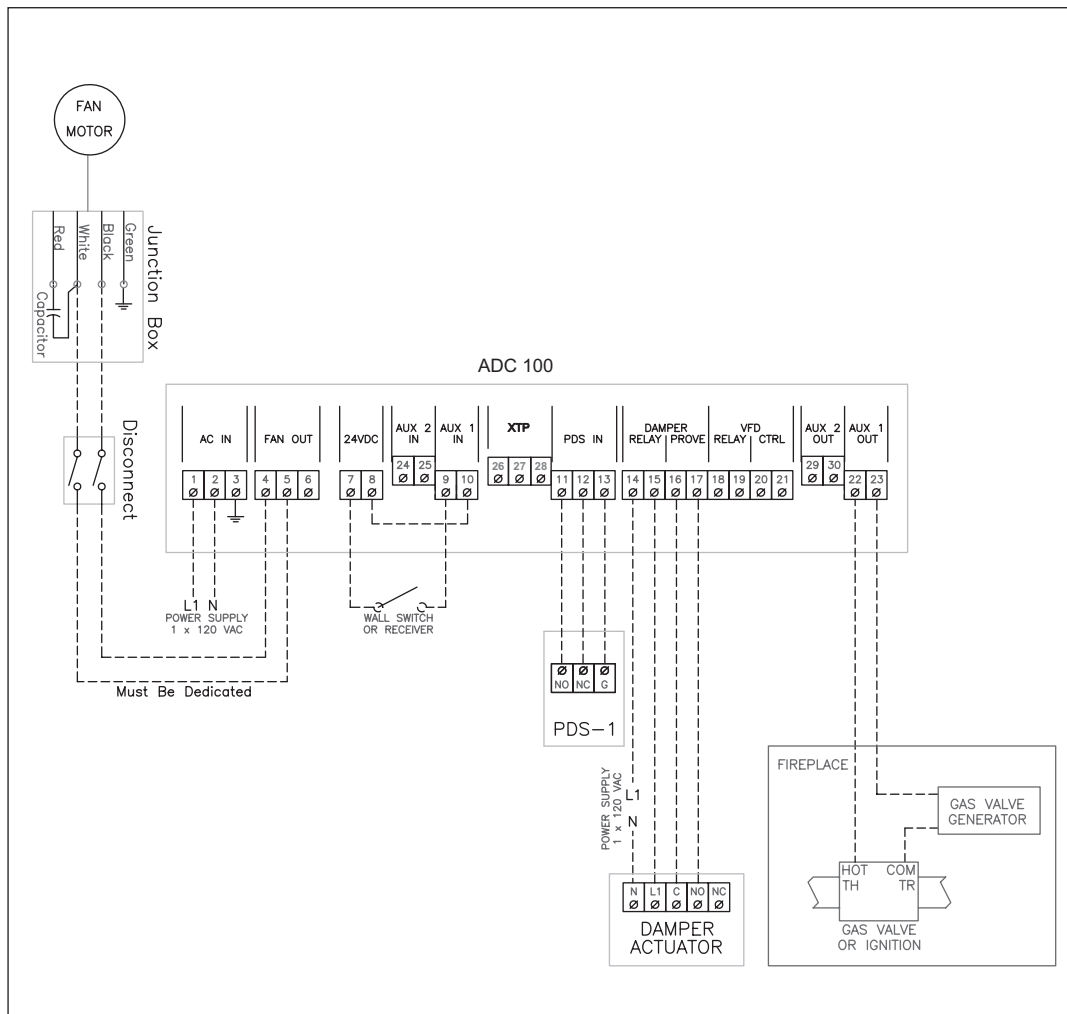

Fig. 9

4.5 WIRING A 3-PHASE FAN

Connect a 3-phase fan to the control system via a variable frequency drive (VFD). The VFD receives external 3-phase power (208-230 or 400-480 VAC). A 0-10 VDC signal from the ADC100 is converted to a 0-60 Hz signal from the VFD to modulate the fan speed. Any appliance(s) or damper should be connected as shown in Fig 8 and 9.

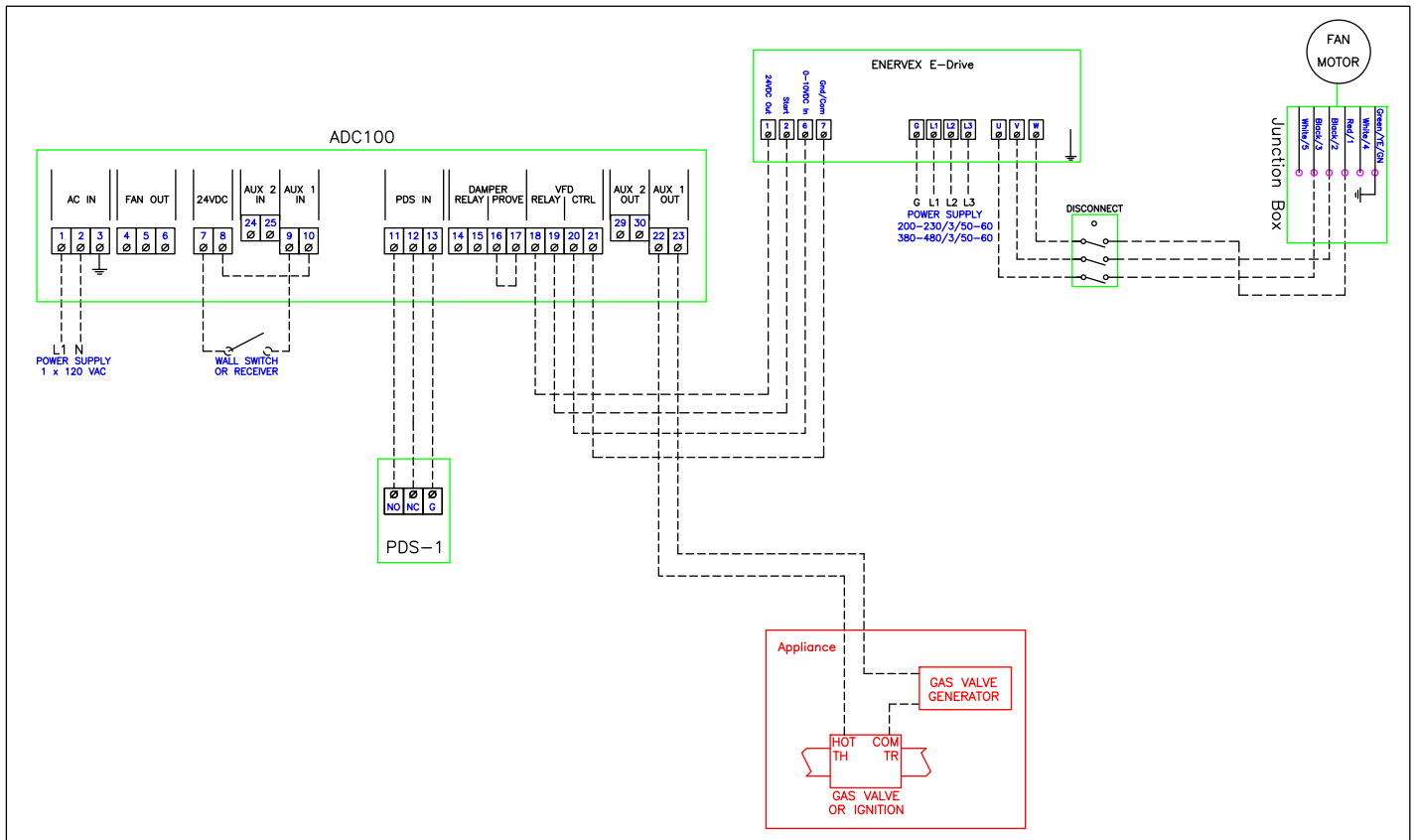

Fig. 10

5. STARTUP AND CONFIGURATION

5.1 GENERAL

Dip switches are located on the control board to allow the user to specify certain functions of the ADC100. Verify settings using the table below.

DIP SWITCH	NAME	OFF	ON	DEFAULT POSITION
1 (Left)	MANUAL RESET	Automatic reset at power failure or insufficient draft	Manual reset at power failure or insufficient draft	OFF
2 (Center)	MANUAL ADJ	Automatic Mode-control speeds up fan if PDS opens during operation	Manually adjust fan speed using potentiometer	OFF
3 (Right)	PDS CHECK*	No monitoring to see if the PDS was in NC position prior to start	The PDS must be in NC position prior to start	ON

NOTE: Do NOT turn PDS check off unless requested by the factory technical support.

5.2 SEQUENCE OF OPERATION

The sequence of operation flow chart is shown in Figure 11 below.

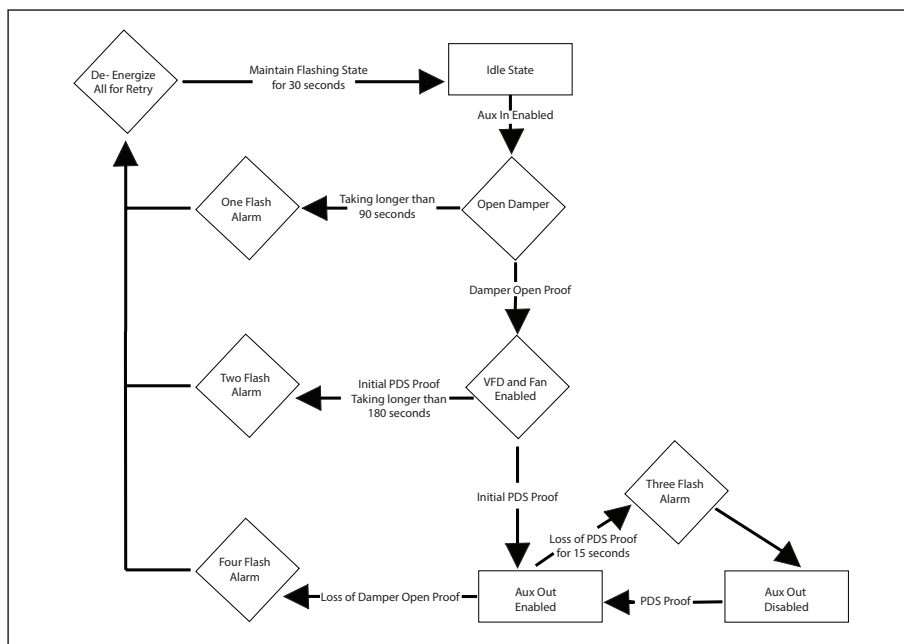

Fig. 11

Alarm Stages

Flashes 1 - if damperprove does not close 90 seconds after auxin, go into alarm for 30 seconds, followed by a full retry

Flashes 2 - if initial pdsprove does not close 180 seconds after damperprove, go into alarm for 30 seconds, followed by a full retry

Flashes 3 - if pds loses proof for 15 seconds after initial pdsprove, auxouts de-energize, stay in alarm until pdsprove returns and auxout will re-energize

Flashes 4 - if at any point after auxout proves the damperprove is removed, the board immediately goes into alarm for 30 seconds, followed by a full retry

Flashes 5 - *must have sw3 on* if pds is proved prior to auxin, board will go into alarm and no further states can be achieved until proof is removed

Start Sequence

1. A call for heat from the appliance energizes the ADC100 inputs at terminals 9 and 10.
2. If a damper is connected, it begins to open. Once open, the damper prove contact closes (Terminals 16 and 17).
3. The ADC100 begins to ramp up the fan.
4. The Proven Draft Switch closes when adequate draft is achieved and ADC100 adjusts fan to speed setting on the potentiometer.
5. The ADC100 control releases the appliance for operation by closing dry contact between terminals 22 and 23 (and terminals 29 and 30).

Operating Sequence

Manual Mode:

1. Fan runs at a constant speed and can be adjusted during normal operation using the potentiometer.
2. If the Proven Draft Switch opens, a 15 second timing cycle starts.
3. If the Proven Draft Switch has not been made within 15 seconds, the auxiliary out contact opens and an alarm condition exists.
4. If the Proven Draft Switch closes, the control automatically resumes normal operation at set speed.

Automatic Mode:

1. Fan runs at speed setting of the potentiometer but cannot be adjusted using the potentiometer during operation.
2. If the Proven Draft Switch opens, the fan begins to ramp up.
3. If PDS closes, fan speed remains at that speed.
4. If the PDS has not closed by the time the fan has ramped up to 100% speed, a 10 second timing cycle begins.
5. If PDS does not close within 15 seconds the auxiliary out contact opens and an alarm condition exists.
6. If the Proven Draft Switch closes while the control is in alarm, the fan will resume the original speed setting.

Shutdown Sequence

1. The call for heat signal from the appliance is turned off.
2. Fan output continues at pre-set speed for the set post purge time (0-3 minutes).
3. Fan output is set to zero.

5.3 OPERATING PRESSURE

The operating pressure of the ADC100 Control is determined by the PDS switch. The PDS-1 used with the ADC100 has a pressure setting of 0.05" W.C. +/- 0.03" W.C. As long as the pressure is within this range, the fireplace and/or appliance will continue to operate. Should the pressure fall outside of this range, it may be necessary to adjust the fan speed. The user may use a manometer or other device to read the pressure inside the stack.

For fireplaces, a standard smoke/ flame test should be performed before normal operation (specified in appliance manual). This test will determine if the fan is running at the correct speed.

6. MAINTENANCE AND TROUBLESHOOTING

Observation	Problem	Solution
Heating appliance/fireplace cycle on and off	Potentiometer setting is too low	Turn potentiometer clockwise to increase fan speed
Fan is 'hunting' (increasing speed and then decreasing speed constantly)	Fan speed control is set too low	Increase potentiometer setting
	Draft in chimney fluctuates	Move Stack Probe closer to fan
Fan will not come on	ADC100 is not wired correctly	Check wiring and correct
	There may be sufficient natural draft	If the PDS is closed when the start signal is applied, sufficient natural draft exists for the fan to run. The ADC100 can run the fan even during these conditions if dipswitch #1 is set to the ON position to initialize a PDS check during the start up sequence.
	Fan is not working	Check the fan and if necessary, repair or replace. Verify all wiring to fan and control is correct and control is receiving external power.
Heating appliance or fireplace will not come on	Fan is not working No power to the ADC100	Check the fan and if necessary, repair or replace. Verify all wiring to fan and control is correct and control is receiving external power
	Proven draft switch is not properly connected to the chimney	Make sure the probe is properly inserted into the stack, so the tip of the probe is flush with the inside of the chimney
	PDS is not working	Replace relay or switch
Heating appliance/fireplace will not shut off	ADC100 is not wired correctly	Check wiring and correct.

3916067 05.17

ENERVEX ADM & ADF AUTOMATED DAMPER

3903005 08.18

Installation & Operating Manual



READ AND SAVE THESE INSTRUCTIONS!



LISTED
UL File E467733

ENERVEX Inc.
1685 Bluegrass Lakes
Parkway
Alpharetta, GA 30004
USA

P: 770.587.3238
F: 770.587.4731
T: 800.255.2923
info@enervex.com
www.enervex.com

ENERVEX® 
VENTING DESIGN SOLUTIONS



This symbol shows that the ENERVEX ADM/ADF Automatic Dampers are listed in the US and certified for Canada under Underwriters Laboratories Inc. file no. E467733.

IMPORTANT: READ THESE INSTRUCTIONS CAREFULLY PRIOR TO INSTALLATION.

- **EXAMINE ALL COMPONENTS FOR POSSIBLE SHIPPING DAMAGE PRIOR TO INSTALLATION.**
- **PROPER JOINT ASSEMBLY IS ESSENTIAL FOR A SAFE INSTALLATION. FOLLOW THESE INSTRUCTIONS EXACTLY AS WRITTEN. CHECK SECURENESS OF JOINTS UPON COMPLETION OF ASSEMBLY.**

WARNING

Failure to follow these installation instructions could cause FIRE, CARBON MONOXIDE POISONING, and/or DEATH. If you are unsure of installation requirements, contact ENERVEX.

Symbol Legend

The following terms are used throughout this manual to bring attention to the presence of potential hazards, or to important information concerning the product.



DANGER: Indicates an imminent hazardous situation which, if not avoided, will result in death, serious injury or substantial property damage.



WARNING: Indicates an imminent hazardous situation which, if not avoided, may result in personal injury or property damage.

How to use this manual

This installation manual does not contain any system design documentation. System design documentation is available from any authorized ENERVEX representative. Accessories, fans, and variable frequency drives are not covered by this manual. Please refer to these component's individual manuals.

TO REDUCE THE RISK OF FIRE, ELECTRICAL SHOCK OR INJURY TO PERSONS, OBSERVE THE FOLLOWING:

1. Use this unit in the manner intended by the manufacturer. If you have questions, contact the manufacturer at the address or telephone number listed on the front of the manual.
2. Before servicing or cleaning the unit, switch off at service panel and lock service panel to prevent power from being switched on accidentally.
3. Installation work and electrical wiring must be done by a qualified person(s) in accordance with applicable codes and standards.
4. Follow the appliance manufacturer's guidelines and safety standards such as those published by the National Fire Protection Association (NFPA), and the American Society for Heating, Refrigeration and Air Conditioning Engineers (ASHRAE), and the local code authorities.
5. This unit must be grounded.

1. PRODUCT INFORMATION	
1.1 Function.....	3
1.2 Shipping	3
1.3 Warranty	3
2. SPECIFICATIONS AND DIMENSIONS	
2.1 Dimensions and Capacities.....	4
3. MECHANICAL INSTALLATION	
3.1 General.....	5
4. ELECTRICAL INSTALLATION	
4.1 Wiring	6
5. MAINTENANCE	
5.1 General.....	7

1. PRODUCT INFORMATION

1.1 FUNCTION

The ENERVEX ADM/ADF Automatic Damper is a single blade, two position damper powered by an actuator. The ADM/ADF is available in standard stack diameters ranging from 4 to 36 inches. The actuator interlocks with a boiler or gas fireplace to open the damper when the appliance is in use, and close it when the appliance is not in use.

The ADM/ADF is powered by a 120 VAC or 24 VAC/VDC actuator. The actuator is equipped with a fail safe system to open the damper in the event of an electrical or mechanical failure. It has an adjustable NO/NC endswitch to provide damper position open/closed.

The ADM damper is manufactured to connect to chimneys w/o flange connections. The ADF damper is manufactured to connect to chimneys with a standard 1/2" flanged connection. The ADM/ADF is rated for temperatures up to 1400°F (760°C).

The ADM/ADF should be installed with sufficient clearance above the boiler outlet to allow for damper protrusion into the stack when fully open. ADM/ADF nameplates located as shown on diagram below.

It is for installation with gas-fired or oil-fired equipment only.

1.2 SHIPPING

- Standard Packing List
- ADM/ADF is shipped completely assembled

1.3 WARRANTY

2-Year Factory Warranty. Complete warranty conditions are available from ENERVEX, Inc.

2. SPECIFICATIONS AND DIMENSIONS

2.1 DIMENSIONS AND CAPACITIES

Model	Stack ID (in)	Dia. A in / mm	Dim. B in / mm	Dim. C in / mm	Dim. D in / mm
ADM 6	6	5.85 / 146	8.0 / 203	7.85 / 199	10.85 / 276
ADM 8	8	7.85 / 197	8.0 / 203	9.85 / 250	12.85 / 326
ADM 10	10	9.85 / 248	10.0 / 254	11.85 / 301	14.85 / 377
ADM 12	12	11.85 / 298	10.0 / 254	13.85 / 352	16.85 / 428
ADM 14	14	13.85 / 349	10.0 / 254	15.85 / 403	18.85 / 479
ADM 16	16	15.85 / 400	10.0 / 254	17.85 / 453	20.85 / 530
ADM 18	18	17.85 / 451	12.0 / 305	19.85 / 504	22.85 / 580
ADM 20	20	19.85 / 502	12.0 / 305	21.85 / 555	24.85 / 631
ADM 22	22	21.85 / 552	14.0 / 356	23.85 / 606	26.85 / 682
ADM 24	24	23.85 / 603	14.0 / 356	25.85 / 657	28.85 / 733
ADM 26	26	25.85 / 654	16.0 / 406	27.85 / 707	30.85 / 784
ADM 28	28	27.85 / 705	16.0 / 406	29.85 / 758	32.85 / 834
ADM 30	30	29.85 / 756	16.0 / 406	31.85 / 809	34.85 / 885
ADM 32	32	31.85 / 806	16.0 / 406	33.85 / 860	36.85 / 936
ADM 34	34	33.85 / 857	18.0 / 457	35.85 / 911	38.85 / 987
ADM 36	36	35.85 / 908	18.0 / 457	37.85 / 961	40.85 / 1038

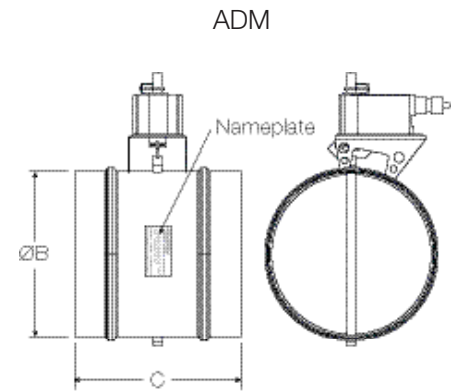

Model	Stack ID in / mm	Dim. A in / mm	Dim. B in / mm	Dim. C in / mm
ADF 4	4	3.94 / 100	4.88 / 124	8.86 / 225
ADF 6	6	5.91 / 150	6.85 / 174	10.83 / 275
ADF 8	8	7.87 / 200	8.82 / 224	12.80 / 325
ADF 10	10	9.84 / 250	10.79 / 274	14.76 / 375
ADF 12	12	11.81 / 300	12.76 / 324	16.73 / 425
ADF 14	14	13.78 / 350	14.72 / 374	18.70 / 475
ADF 16	16	15.75 / 400	16.69 / 424	20.67 / 525
ADF 18	18	18.00 / 457	19.00 / 483	23.00 / 584
ADF 20	20	20.00 / 508	21.00 / 533	25.00 / 635
ADF 22	22	22.00 / 559	23.00 / 584	27.00 / 686
ADF 24	24	24.00 / 610	25.00 / 635	29.00 / 737
ADF 26	26	26.00 / 660	27.00 / 686	31.00 / 787
ADF 28	28	28.00 / 711	29.00 / 737	33.00 / 838
ADF 30	30	30.00 / 762	31.00 / 787	35.00 / 889
ADF 32	32	32.00 / 813	33.00 / 838	37.00 / 940
ADF 34	34	34.00 / 864	35.00 / 889	39.00 / 991
ADF 36	36	36.00 / 914	37.00 / 940	41.00 / 1041

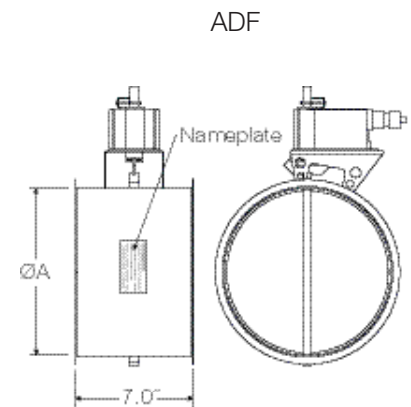

Other sizes available upon request.

3. MECHANICAL INSTALLATION

3.1 GENERAL

The ADM has male-male slip connections. Install the ADM in the vent system at least one vent diameter (B) plus one foot above an appliance outlet and at least three vent diameters away from any tee or elbow.

The ADF has standard flanged connections. Install using the accompanying V-Band and a gasket seal. Install the ADF in the vent system at least one vent diameter (A) plus one foot above an appliance outlet and at least three vent diameters away from any tee or elbow as shown in the figures on the right.

DO NOT COVER ACTUATOR WITH INSULATION.

THE ADM AND ADF ARE FOR INSTALLATION WITH GAS-FIRED OR OIL-FIRED EQUIPMENT ONLY.

MINIMUM CLEARANCE TO COMBUSTIBLE IS 18".

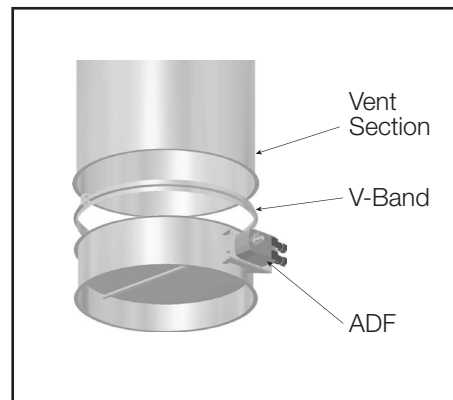
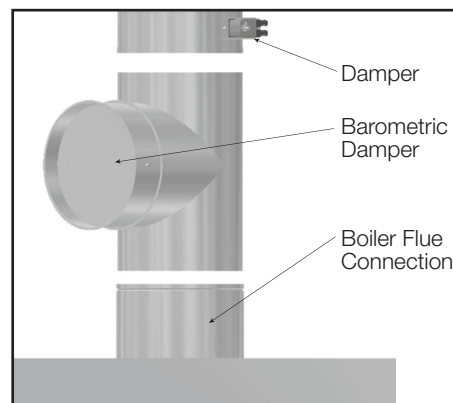
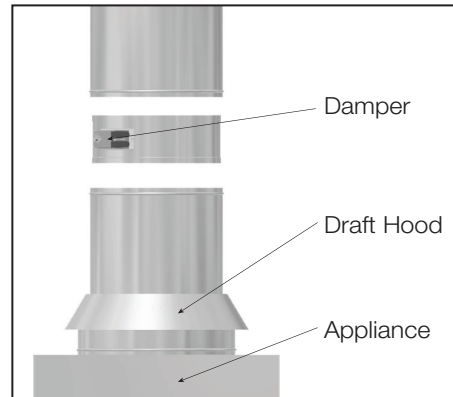

4. ELECTRICAL INSTALLATION

4.1 WIRING

DANGER



Turn off electrical power before servicing. Contact with live electric components can cause shock or death.

Éteignez l'alimentation électrique avant de procéder à l'entretien. Le contact avec des composants électriques sous tension peut provoquer un choc ou la mort.



Verify voltage of actuator before connecting to a power supply. Actuator will run on either 120VAC or 24VAC/VDC.

Vérifiez la tension de l'actionneur avant de le connecter à une source d'alimentation. Actuator fonctionnera sur 120VAC ou 24VAC / VDC.

Wire that actuator for 2 wire/ 2 position operation as shown in Figure 1 (120 VAC) and Figure 2 (24 VAC) on the right.

The actuator should be set for clockwise (CW) rotation and should fail to the ADM/ADF open position. Verify settings of the actuator before installation.

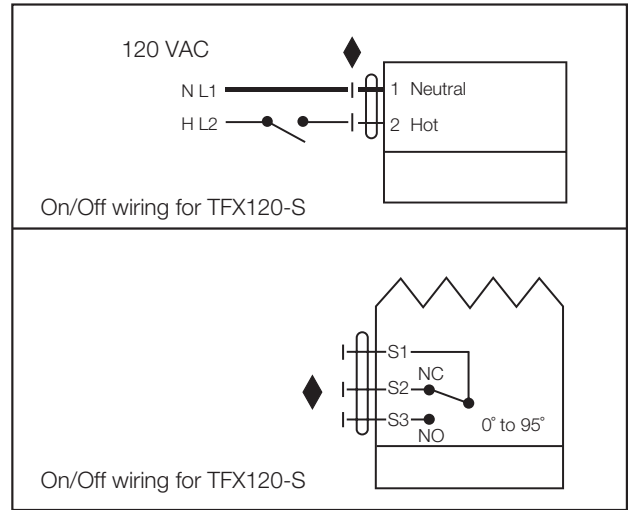

Fig. 1 120 VAC Actuator

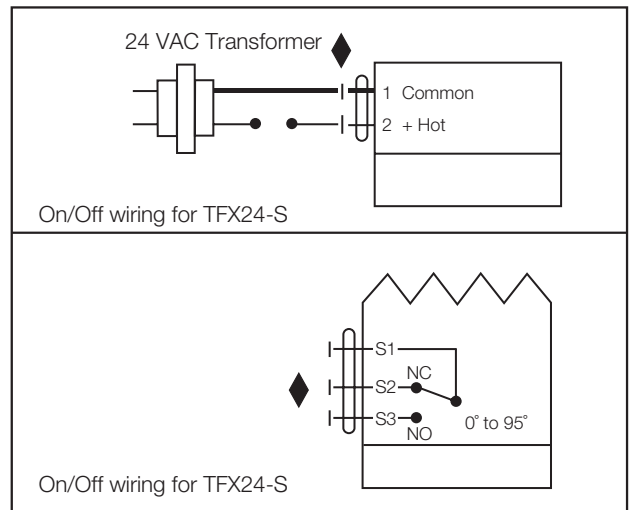

Fig. 2 24 VAC/VDC Actuator

5. MAINTENANCE

5.1 GENERAL

Annual maintenance is recommended. During the maintenance check, verify the damper blade is in the correct position (the indicator on the damper rod will show the position of the damper blade). Check that the damper rod is firmly secured by the actuator and tighten fasteners if necessary.

ENERVEX Inc.
1685 Bluegrass Lakes
Parkway
Alpharetta, GA 30004
USA

P: 770.587.3238
F: 770.587.4731
T: 800.255.2923
info@enervex.com
www.enervex.com

ENERVEX® 
VENTING DESIGN SOLUTIONS

ENERVEX RS CHIMNEY FAN FOR GAS & OIL APPLICATIONS

3000270 08.17

Installation & Operating Manual

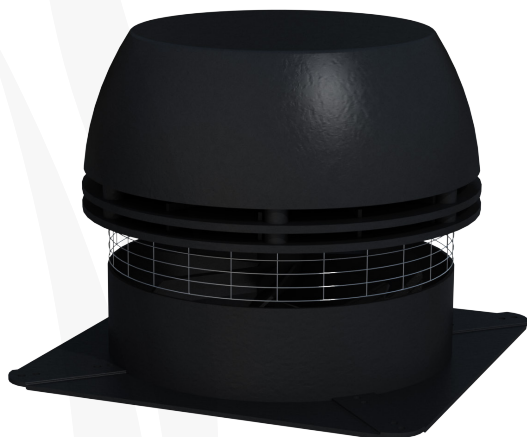

READ AND SAVE THESE INSTRUCTIONS!



Intertek
ETL514733

ENERVEX Inc.
1685 Bluegrass Lakes
Parkway
Alpharetta, GA 30004
USA

P: 770.587.3238
F: 770.587.4731
T: 800.255.2923
info@enervex.com
www.enervex.com

ENERVEX® 
VENTING DESIGN SOLUTIONS



This symbol shows that ENERVEX RS Chimney Fans for solid fuel applications are listed under ETL File no. 514733.

Symbol Legend

The following terms are used throughout this manual to bring attention to the presence of potential hazards, or to important information concerning the product.



DANGER: Indicates an imminent hazardous situation which, if not avoided, will result in death, serious injury or substantial property damage.



WARNING: Indicates an imminent hazardous situation which, if not avoided, may result in personal injury or property damage.



DANGER: Indicates an imminent electrical shock hazard which, if not avoided, will result in death, serious injury or substantial property damage.

How to use this manual

This installation manual does not contain any system design documentation. System design documentation is available from any authorized ENERVEX representative. Accessories, fans, and variable frequency drives are not covered by this manual. Please refer to these component's individual manuals.

TO REDUCE THE RISK OF FIRE, ELECTRICAL SHOCK OR INJURY TO PERSONS, OBSERVE THE FOLLOWING:

1. Use this unit in the manner intended by the manufacturer. If you have questions, contact the manufacturer at the address or telephone number listed on the front of the manual.
2. Before servicing or cleaning the unit, switch off at service panel and lock service panel to prevent power from being switched on accidentally.
3. Installation work and electrical wiring must be done by a qualified person(s) in accordance with applicable codes and standards.
4. Follow the appliance manufacturer's guidelines and safety standards such as those published by the National Fire Protection Association (NFPA), and the American Society for Heating, Refrigeration and Air Conditioning Engineers (ASHRAE), and the local code authorities.
5. This unit must be grounded.

Content

1. GENERAL INFORMATION	
1.1 Function	4
1.2 Shipping.....	4
1.3 Warranty.....	4
2. SPECIFICATIONS AND DIMENSIONS	
2.1 Dimensions and Capacities	5
2.2 Planning Ahead	6
3. MECHANICAL INSTALLATION	
3.1 Transport Safety Device.....	7
3.2 Single Fan on Steel Chimney	7
3.3 Single Fan on Brick Chimney	8
3.4 Multiple Fans on Steel Chimney	9
3.5 Multiple Fans on Brick Chimney - Oversized Flue.....	9
3.6 Installation for High Temperatures.....	9
3.7 Wall Mounting of Chimney Fan	10
3.8 Installation of Proven Draft Switch (PDS).....	10
3.9 Termination of Venting System.....	10
4. ELECTRICAL INSTALLATION	
4.1 General	12
4.2 Wiring Diagram for Single Fan with FSC	12
4.3 Wiring for Two Fans with FSC.....	13
4.4 Wiring Diagram for Single Fan with ADC 100.....	13
5. STARTUP AND CONFIGURATION	
5.1 System Testing	14
5.2 Adjusting the Chimney Fan Speed.....	14
5.3 Adjusting the Proven Draft Switch Setting.....	14
6. MAINTENANCE AND TROUBLESHOOTING	
6.1 Prior to Cleaning.....	15
6.2 Care and Cleaning.....	15
6.3 Chimney Cleaning Intervals.....	15
6.3 Troubleshooting.....	16

1. GENERAL INFORMATION

1.1 FUNCTION

The RS Chimney Fan is a chimney top mounted ventilator that is designed to provide large flue gas volume capacities. It is designed and intended for use with residential gas or oil fired central space heating systems, for volume water heating or for combination space heating/volume water heating. It is also suitable for use with gas-fired fireplaces, stoves, BBQ's or residential pizza ovens.

This product is developed to prevent draft problems from occurring by creating a mechanical draft in venting systems and thereby also increasing the capacity and efficiency of a venting system.

The use of the RS Chimney Fan is not restricted to any type of chimney, because the fan creates a negative pressure (below atmospheric) in the chimney or vent.

Code Compliance

Installations must conform to requirements of the authority having jurisdiction. Where required by the authority having jurisdiction, the installation must also conform to the Standard for Draft Equipment and The National Fuel Gas Code, ANSI Z223.1/NFPA 54.

All electrical wiring must be in accordance with the requirements of authority having jurisdiction or, in the absence of such requirements, with the National Electrical Code, NFPA70.

Listings

The Model RS is tested and listed to UL Standard 378, Standard for Draft Equipment. The fan is manufactured at an ISO9001 certified plant and bears the European CE compliance label.

The chimney fan must be interlocked with the connected appliance(s) to insure proper combustions and to avoid flue gas spillage.

1.2 SHIPPING

The packing list (attached to one of the packages) clearly lists all items in the shipment and each package has a label showing the contents. Check the list against all materials on the job site for completeness.

NOTE: All single phase fans are shipped with a capacitor and junction box connected via conduit. The capacitor is located INSIDE the junction box. Please do not discard.

1.3 WARRANTY

ENERVEX products are warranted for a period of two (2) years following the date of invoice. Replacement or repair will be at ENERVEX's discretion, provided factory inspection shows a defect in material or workmanship.

Complete warranty conditions are available from ENERVEX.

2. SPECIFICATIONS

2.1 DIMENSIONS & CAPACITIES

Model		RS 009	RS 012	RS 014	RS 016	
Discharge		Horizontal				
Fan Type		Axial Vane				
Motor Type		Totally enclosed, Variable speed, Class H				
Voltage	VAC	1x120V @ 60 Hz				
Amperage	Amps	0.5	1.2	1.4	3.9	
RPM		1600				
CFM	@0.0 Ps	450	950	1400	1950	
Motor Output	hp / kW	1/30 / .025	1/10 / 0.08	1/7 / 0.1	1/3 / 0.25	
Weight	lbs / kg	29 / 13	37 / 17	47 / 21	61 / 28	
	kg	13	17	21	28	
Dimensions	A	in / mm	10.2 / 259	11.5 / 292	13.1 / 334	16.0 / 407
	BxB	in / mm	11.7 / 296	14.3 / 364	16.6 / 422	18.8 / 478
	C	in / mm	10.8 / 275	13.5 / 344	15.5 / 395	17.4 / 441
	D	in / mm	3.0 / 75	3.3 / 85	3.9 / 100	3.9 / 100
	E	in	9.4 / 238	11.6 / 294	13.5 / 342	15.4 / 391
Temperature Rating	Interm.	575°F / 300°C				
	Cont.	482°F / 250°C				

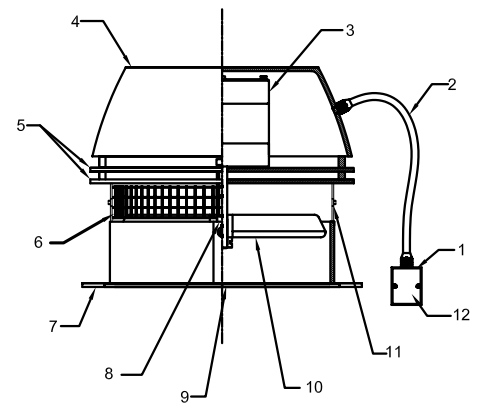
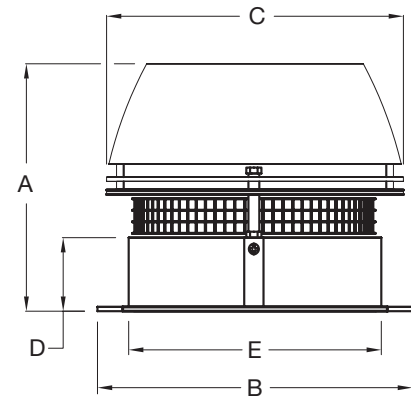

- 1 Junction box
- 2 Conduit/cord
- 3 Motor
- 4 Motor housing
- 5 Motor plate
- 6 Bird screen
- 7 Base plate
- 8 Locking nut
- 9 Inlet
- 10 Axial vane
- 11 Hinges
- 12 Capacitor (inside junction box)

Capacity

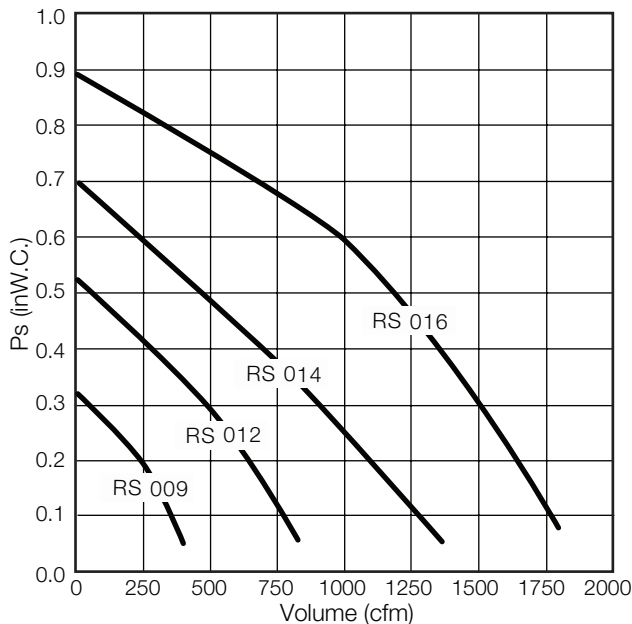

Sound Data

Model	Lw dB (measured in accordance with ISO 3744)							Lp dB(A)
	125Hz	250Hz	500Hz	1000Hz	2000Hz	4000Hz	8000Hz	
RS009	54	50	47	43	38	31	25	21
RS012	64	60	55	52	48	42	34	30
RS014	75	69	65	62	57	51	44	41
RS016	81	76	72	69	64	58	52	47

2.2 PLANNING AHEAD



Observe proper combustion air requirements.
Provide a firm support system for the chimney fan.
Determine the type of system involved.
Observe proper safety measures are taken to assure safe use of the wood burning appliances.

Combustion Air Requirements

Provisions for combustion air must be in accordance with applicable local codes.

If the heating system is installed in an unconfined space, adequate air will be available via normal infiltration.

If the heating system is installed in a confined space, (a space with a volume less than 50 cubic feet per 1,000 Btu/hr of input for all fuel burning equipment) or building construction is unusually tight, adequate air for combustion must be provided by two openings: one located about 6" below the ceiling, the other about 6" above the floor. Each opening must have a minimum free area as follows:

1. One square inch per 4,000 Btu/hr of input when communicating directly with the outside or through a vertical duct.
2. One square inch per 2,000 Btu/hr when communication through horizontal ducts to the outside.
3. One square inch per 1,000 Btu/hr when ventilation air is provided by openings in doors, etc. to adjoining spaces having adequate infiltration.



Adequate fresh air must be provided for combustions; otherwise improper operation and inadequate venting of deadly flue gases may result.

Support system for the chimney fan

Prior to installation of the chimney fan, it must be assured the chimney can safely carry the weight of the chimney fan.

A steel chimney should be well supported at the roof penetration point. If the chimney extends more than 20' above the roof, the chimney and the fan should be secured by wires attached on the chimney and on the roof at 2 to 3 different points.

Brick chimneys usually do not need any kind of support to carry the weight of the chimney fan.

System type

Direct connect oil or gas appliances (no draft hood) normally do not require any mechanical draft adjustment. However, if there are long horizontal breechings and far between the appliances, it is a good idea to install mechanical vent dampers, so adjustments of the draft can be easily made.

Draft hood systems could generally speaking have vent dampers installed. The vent dampers are used to balance the system and assure that only a minimum of dilution air is pulled through the draft hoods.

Safety Devices

Local codes usually require installation of safety devices, when mechanical draft is provided in an oil or gas fueled system.

Make sure a differential pressure switch (proven draft switch) is installed to assure that no appliance will fire unless there is a proven draft.

3. MECHANICAL INSTALLATION

3.1 TRANSPORT SAFETY DEVICE

If a transport safety device is present, remove it from the vane and make sure that the vane can revolve without hindrance.

RS 14/16: Before mounting, the transport safety device on the hinges must be removed.

3.2 SINGLE FAN ON STEEL CHIMNEY

Step 1: Prepare fan location

If a stack cap is already installed, it must be removed. The steel chimney adapter (SCA) slides right into the chimney, where the long collar engagement ensures safe anchoring. If necessary, the adapter can be secured by means of long self-tapping stainless steel screws into the side of the collar through the chimney wall.

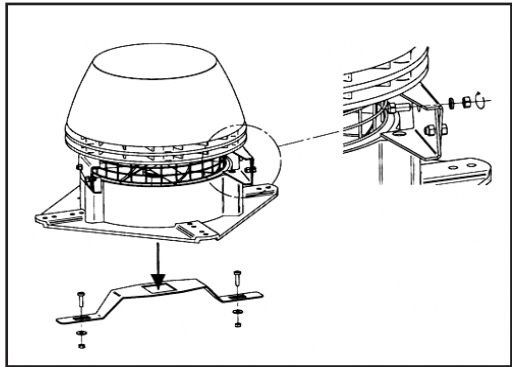

If the steel chimney is air-cooled, a special adapter for such chimney must be used.

Measure the inside diameter of the flue and cut a corresponding hole in the center of the fiber mat. If the flue is so big that the throat in the adapter has been reduced to fit the throat of the fan, the hole in the fiber mat should correspond to the throat.

The aluminum foil on the fiber mat must face upward (against fan base).

Step 2: Preparation of fan

Locate the installation brackets in the grooves on the underside of the fan base, using the bolts and nuts supplied to secure the brackets. Note that the bolts shall be installed from the bottom side in the two inner holes.

Adjust the final position of the installation brackets ensuring that there is a small gap between the brackets and the flue wall/adapter throat. Tighten the nuts. If the brackets touch the flue wall, it may create some vibration noise.

Step 3: Attaching the fan

The chimney fan is now ready for installation on the top of the chimney. Place the fiber mat with the aluminum foil facing upwards on the top of the adapter, and place the fan on top of the mat. High temperature silicone can be applied on the side of the mat, but is not required. It can also be painted. It is not necessary to bolt the fan to the chimney.

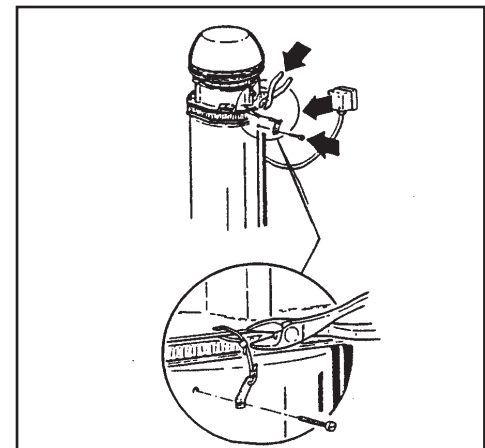
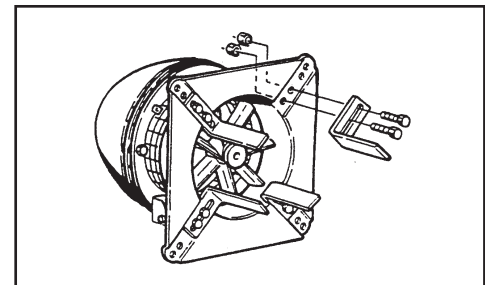
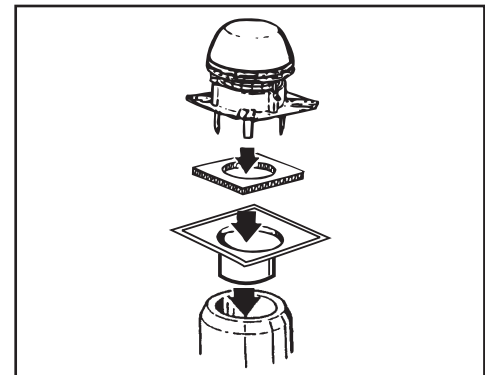

CAUTION

Under conditions with extremely strong winds surrounding the top of the chimney, the chimney fan must be secured by steel wires supplied with the fan.

3.3 SINGLE FAN ON BRICK CHIMNEY

Step 1: Prepare fan location

The installation procedure is the same whether the flue is round or square. If a clay tile flue liner is installed, it might stick up a few inches. Cut it back so it is flush with or no more than 1/2 inch above the chimney crown.

Measure the inside diameter of the flue, cut a corresponding hole in the fiber mat leaving a minimum distance of 3/4" to any side of the fiber mat.

The aluminum foil on the fiber mat must face upwards (against fan base).

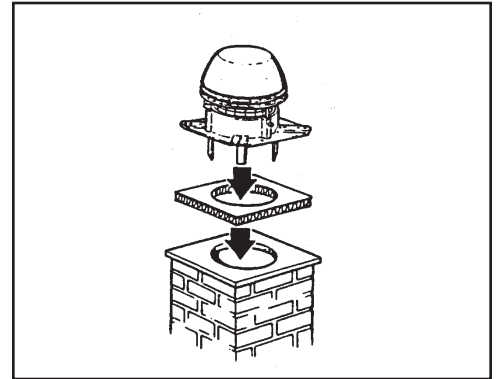

Step 2: Preparation of fan

Locate the installation brackets in the slots going through the fan base, using the bolts and nuts supplied to secure the brackets. If the flue diameter is larger than the chimney fan inlet, the bracket can be installed underneath the base. Note that the bolts must be installed from the bottom side.

Adjust the final position of the brackets ensuring that there is clearance between the brackets and the flue wall. If the brackets touch the wall, it may generate some vibration noise.

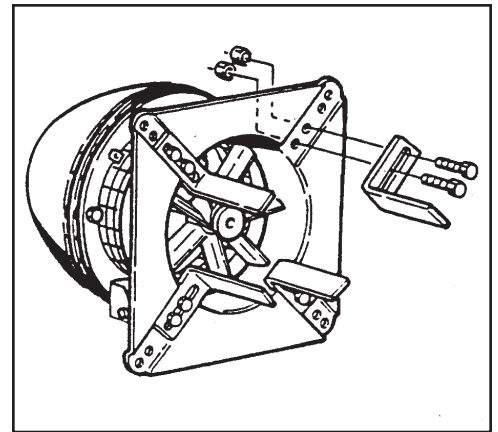

Step 3: Attaching the fan

The chimney fan is now ready for installation on the top of the chimney. Place fiber mat with the aluminum foil facing upwards on the top of the chimney, and place the fan on top of the mat.

High temperature silicone can be applied on the side of the mat, but is not required. It can also be painted.

It is not necessary to bolt the fan to the chimney.

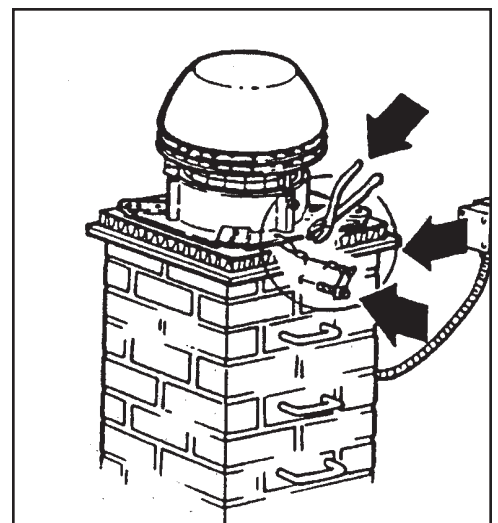

CAUTION



Under conditions with extremely strong winds surrounding the top of the chimney, the chimney fan must be secured by steel wires supplied with the fan.

3.4 MULTIPLE FANS ON STEEL CHIMNEY

If two or more chimney fans are required to create sufficient draft, installation procedures are the same as for single fan installation on a steel chimney. The only difference is that the fans are sitting next to each other on the top of the chimney. A special adapter plate is required.

When installing multiple fans, it is extremely important that the fans are of the same model and size, and they must be controlled in tandem by one (1) motor speed control.

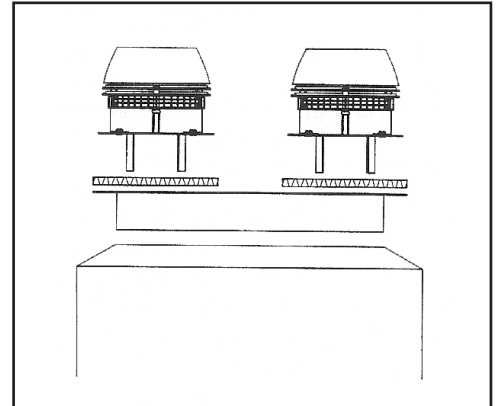

3.5 MULTIPLE FANS ON A BRICK CHIMNEY - OVERSIZED FLUE

If two or more fans are required to create sufficient draft, a special adapter plate is required. The adapter plate should be made of stainless steel (14 GA or thicker), depending on the size and the fan models used.

The two holes in the plenum box should match the throat diameter of the fan model used and the distance from center to center should be at least equal to the fan width (dimension "B" in 1.5. Dimensional data).

The adapter should be sealed with silicone and bolted onto the top. When installing multiple fans, it is extremely important that the fans are of the same model and size, and they must be controlled in tandem by one (1) motor speed control.

A similar approach should be taken if the flue size exceeds the fan base dimensions. The adapter plate should be sized so it covers the flue and secured. A hole should be cut in the center of the plate and the fan mounted centered over the hole.

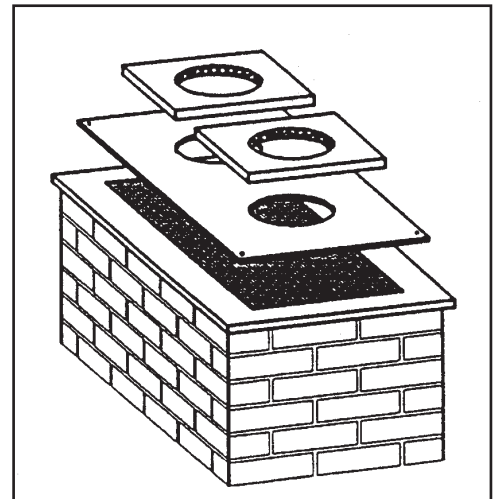

3.6 INSTALLATION FOR HIGH TEMPERATURES

If the fan is used for applications where the flue gas temperatures exceed 400°F at the flue exit, and does not exceed 650°F, dilution bolts must be used.

Dilution bolts will cause cool air to dilute the warm flue gas, by lifting the fan and leaving space so the cool air can get in under the fan base.

The dilution bolts should be installed in the outer holes in the fan base.

The dilution bolts are adjustable and should be adjusted so the flue gas temperature does not exceed 400°F when discharged through the fan. When using dilution bolts the fan's actual capacity is reduced and a stronger model may be required. The fiber mat is not required when using dilution bolts.

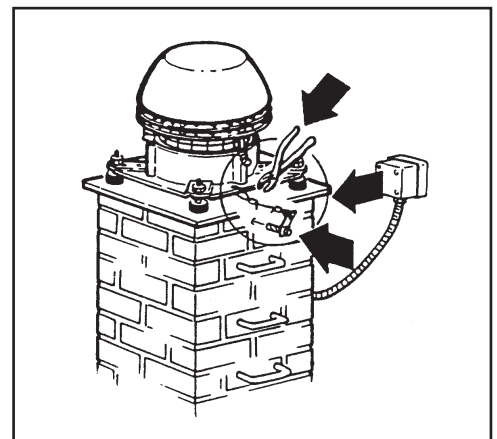

3.7 WALL MOUNTING OF CHIMNEY FAN

When mounting the chimney fan on a wall, the installation instructions for installation on a steel chimney should be followed. Use of the adapter SCA can make the installation easier, but is not a requirement.

To ease installation, detach the fan base by removing the bolts holding the hinges together. Center the fan base over the outlet and bolt the base onto the wall with the hinges pointing upwards.

After mounting the base securely, attach the fan motor housing by reassembling the fan hinges. Seal with silicone all around the fiber mat to prevent rain from entering the flue.

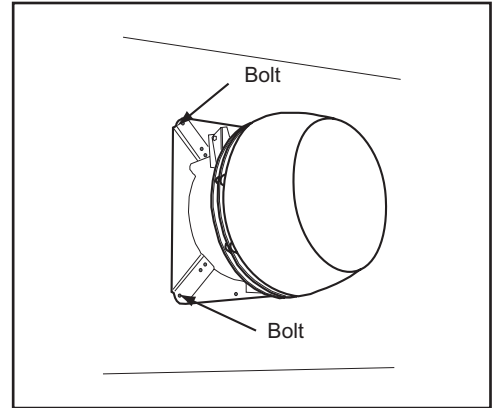

3.8 INSTALLATION OF PROVEN DRAFT SWITCH (PDS)

A safety system must be interlocked with the appliance(s). The safety system could utilize a Proven Draft Switch, a thermal switch or a flow switch. The device must be interlocked with the heating appliance so it shuts down in case of insufficient draft, fan failure or power failure. Please refer to the PDS Installation Manual if this control is used.

For more information on alternative safety systems, please contact ENERVEX, Inc.

The figure shows the location of the probe for the PDS. Location is important to make sure there is enough pressure or draft available or the switch to work.

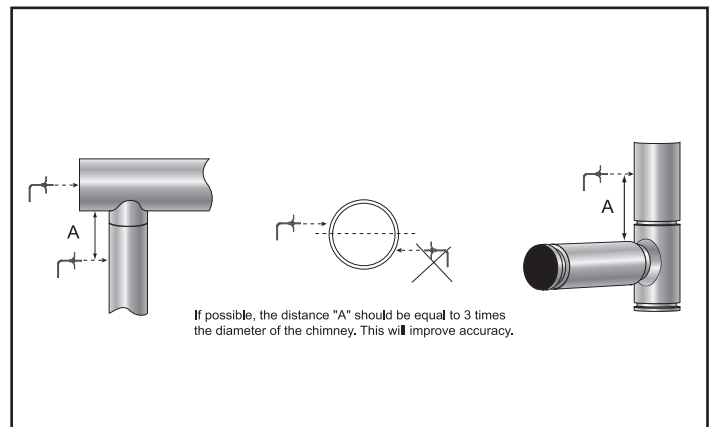

CAUTION

A safety device that prevents the heating appliance operation, in case of a power failure or inadequate draft situation, must be installed.

3.9 TERMINATION OF VENTING SYSTEM

In order to achieve optimal performance and energy consumption for the RS Fan or GSV Fan, the duct must be installed as shown below and the distances observed. From the last elbow to the termination point the distance has to be 3 times the diameter of the flue. For example if you using 12in flue (12 X 3 = 36in). So the distance from the last elbow to the fan termination point should be 36 inches..

A venting system that terminates in the sidewall of a structure shall terminate at least 3 ft (0.9 m) above any air inlet to the structure that is within 10 ft (3 m) of the termination point.

Exception No. 1: This requirement shall not apply to the combustion air intake of a direct vent appliance.

Exception No. 2: This requirement shall not apply to the separation distance between the circulating air inlet and the vent discharge of a listed outdoor appliance.

The flue gas outlet of an appliance other than a direct vent appliance shall terminate at least 4 ft (1.2 m) below, 4 ft (1.2 m) horizontally from, or 1 ft (0.3 m) above any door, window, or gravity air inlet of the structure. The outlet also shall terminate at least 1 ft (0.3 m) above grade.

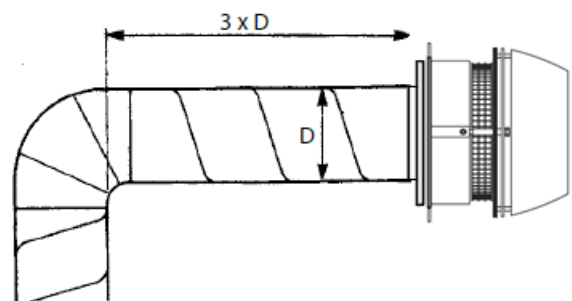

The combustion air inlet and flue gas outlet of a direct vent appliance or the flue gas outlet of an appliance other than a direct vent appliance shall terminate at least 1 ft (0.3 m) from the soffit of the roof of the structure and at least 3 ft (0.9 m) from an inside corner of an L-shaped structure.

The flue gas outlet terminal of a direct vent application with an input of 50,000 Btu/hr (0.35 gal/hr) or less shall be located at least 9 in. (230 mm) from any door, window, or air inlet to the structure. The vent terminal of a direct vent appliance with an input over 50,000 Btu/hr (0.35 gal/hr) shall be located at least 1 ft (0.3 m) from any door, window, or air inlet to the structure. Regardless of input, the flue gas outlet terminal shall also terminate at least 1 ft (0.3 m) above grade.

The exit terminals of mechanical draft systems shall not be less than 7 ft (2.1 m) above grade when located adjacent to public walkways.

Any air inlet and any flue gas outlet of any appliance shall terminate at least 5 ft (1.6 m) from the vent outlet of a supply tank.

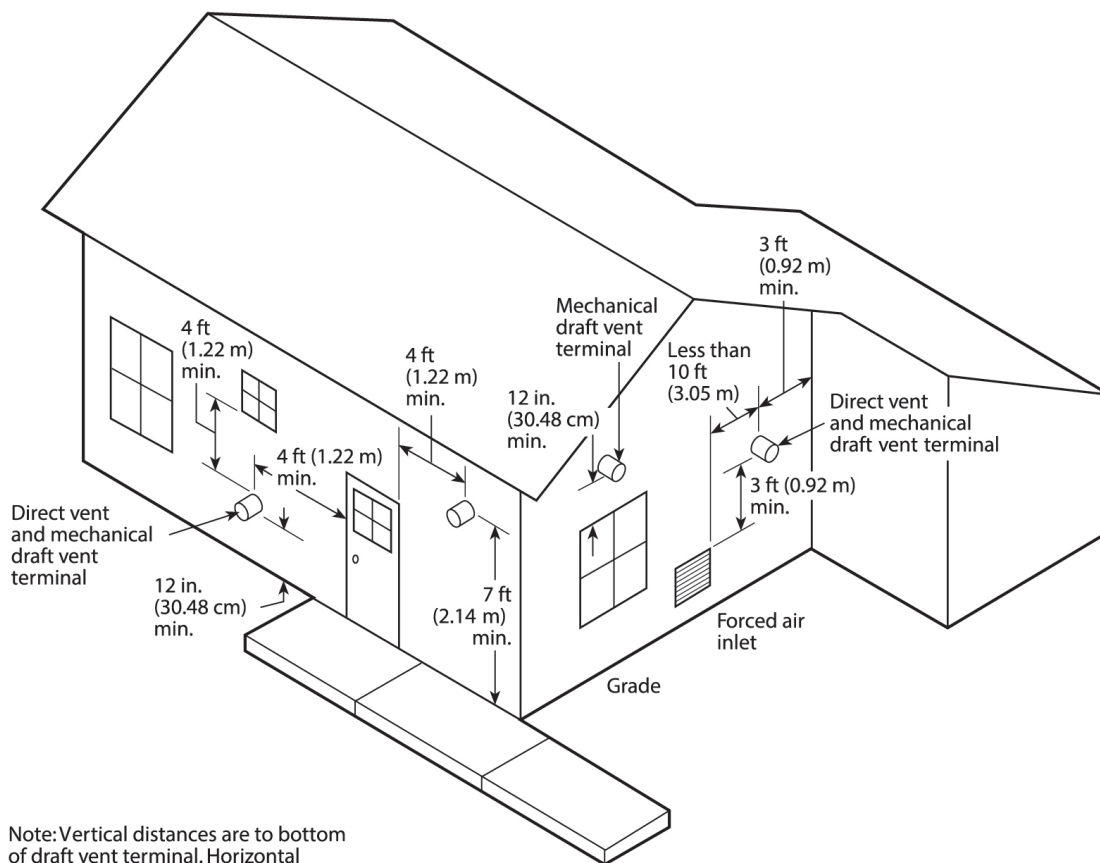

Note: Vertical distances are to bottom of draft vent terminal. Horizontal distances are to center line.

Source: NFPA 31: Standard for the Installation of Oil-Burning Equipment

4. ELECTRICAL INSTALLATION

4.1 GENERAL

DANGER



Turn off electrical power before servicing.
Contact with live components can cause shock or death.

All electrical wiring must be in compliance with the local codes or in their absence, with the National Electric Code, NFPA 70 — latest edition. If an external electrical source is utilized, system must be electrically grounded in accordance with requirements of the authority having jurisdiction or, in the absence of such requirements, with the National Electrical Code NFPA 70 — latest edition.

Power requirements for the system depends on the fan size. Electrical requirements are:

- RSHT009 1 x 120 V/60 Hz 0.4 Amps
- RSHT012 1 x 120 V/60 Hz 1.2 Amps
- RSHT014 1 x 120 V/60 Hz 1.4 Amps
- RSHT016 1 x 120 V/60 Hz 3.9 Amps

The chimney fans have a split capacitor motor with infinitely variable speed.

The fan speed control supplied is rated 1 x 120 V/60 Hz and 5 Amps. It has an adjustable low voltage set point of min. 65 V +/- 5 V.

4.2 WIRING DIAGRAM FOR SINGLE FAN WITH FAN SPEED CONTROL

The wiring diagram at right shows the wiring of the chimney fan and how it is connected to the fan speed control.

NOTICE



If any of the original wire supplied with the system must be replaced, use similar wire of the same temperature rating. Otherwise, insulation may melt or degrade, exposing bare wire.

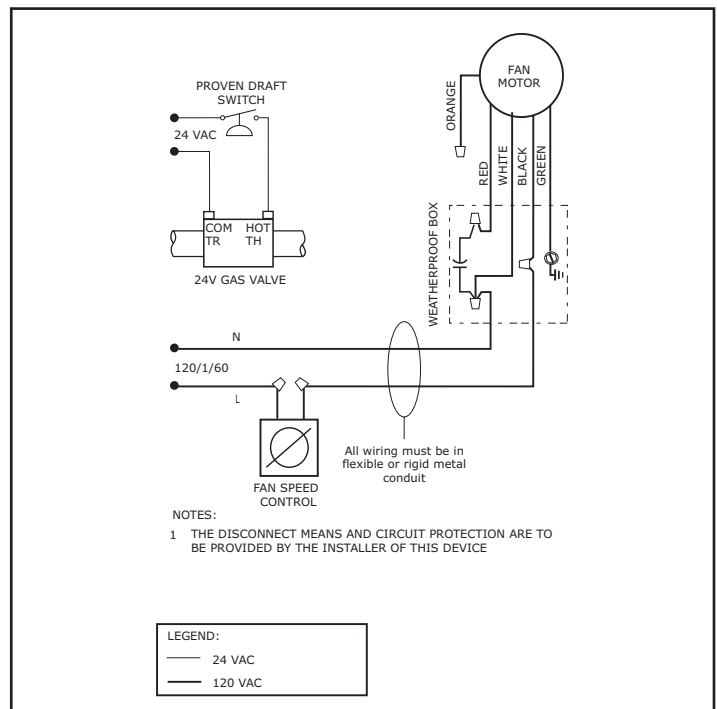

4.3 WIRING DIAGRAM FOR TWO FANS WITH FAN SPEED CONTROL

The diagrams at right show the wiring of two chimney fans and how they are connected to the fan speed control.

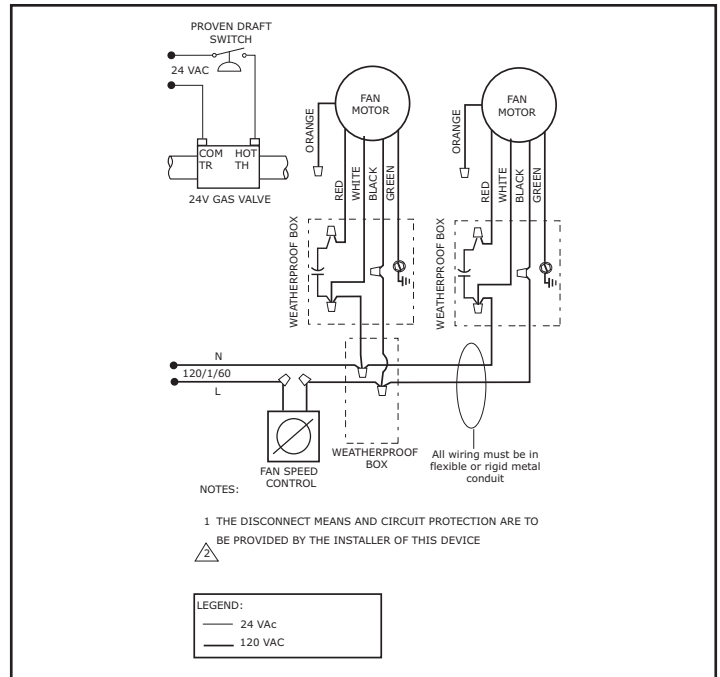

4.4 WIRING DIAGRAM FOR SINGLE FAN WITH ADC-100

The diagrams at right show the wiring of a single chimney fan when used in conjunction with an ADC 100P or ADC 100-E Control.

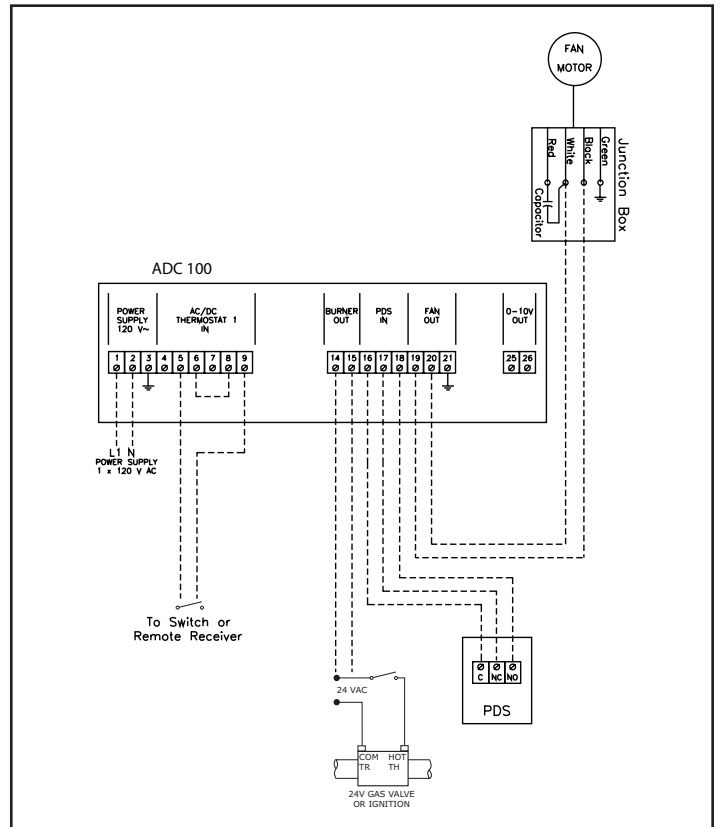

5. STARTUP AND CONFIGURATION

5.1 SYSTEM TESTING

Before any adjustments are made to the system, follow these procedures:

1. Turn the chimney fan ON and make sure that it is operating. Increase and decrease the speed of the fan by adjusting the fan speed control to make sure it is operating properly.
2. Turn the fan OFF and make sure the pressure switch opens, on the power to the circuit it controls is disconnected.

DANGER



Check other heating appliances (water heater, furnace, etc.) for proper operation while the chimney fan is operating. Make sure no flue gases are spilling out as this can lead to carbon monoxide poisoning.

5.2 ADJUSTING THE CHIMNEY FAN SPEED

Start up all appliances. Use the fan speed control to set the speed of the chimney fan so no back pressure is experienced anywhere in the system. Check the system for flue gas spillage. Mark this setting on the fan speed control cover.

5.3 ADJUSTING THE PROVEN DRAFT SWITCH SETTING

Remove the snap-on cover from the conduit enclosure by loosening its retaining screw. Turn the slotted Adjustment Screw clockwise to raise the set point pressure and counter clockwise to lower the set point.

Set the adjustment to its lowest position. With all appliances operating, reduce the speed of the fan to the set point, where the appliance(s) starts to spill flue gas. Increase the speed of the fan gradually to the point where there is no more spillage. Raise the switch's set point so it opens. Return the fan speed to the original setting marked on the cover.

The system is now adjusted so the flue gas spillage will disconnect the heating appliance(s).

The procedure described here may not cover all Proven Draft Switches, so please review the Installation Manual for the switch being used.

6. MAINTENANCE AND TROUBLESHOOTING

6.1 PRIOR TO CLEANING

Remove butterfly nut or screw from each hinge prior to cleaning.

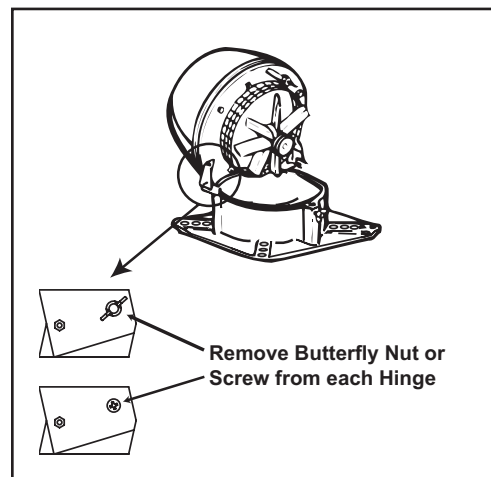

6.2 CARE AND CLEANING

The Chimney Fan System is designed for prolonged use. The fan should be inspected at least one a year when the chimney is inspected. Fuel residues and other deposits should be removed from the fan blades and the bottom of the motor housing.

The top of the fan is hinged and can be opened in order to ease the cleaning.

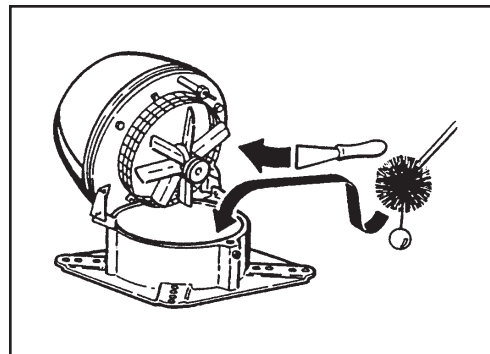

NOTICE



If any of the original wire supplied with the system must be replaced, use similar wire of the same temperature rating. Otherwise, insulation may melt or degrade, exposing bare wire.

6.3 CHIMNEY CLEANING INTERVALS

It is extremely important to keep the chimney flue clean from combustion and deposits. Unburned oil residues can cause chimney fires.

Cleaning intervals depend on the use of the appliance. The more the appliance is used, the more often the chimney flue needs cleaning. As there are no firm guidelines for cleaning intervals, have the chimney inspected on a regular basis (every quarter or so) to determine what the interval should be. Then follow this interval.

No matter how much used, a chimney flue should be cleaned and inspected at least once every year.

NOTE:

The chimney should be cleaned by a trained professional.

We recommend using a Certified chimney sweep certified by Chimney Safety Institute of America.

You can find a Certified Chimney Sweep at www.csia.org or www.ncsg.org or by calling (317) 837-5362 or (317) 837-1500.

6.4 TROUBLESHOOTING

Observation	Problem	Solution
There is no power going to the fan	<ul style="list-style-type: none"> – The circuit breaker may be off – Fan speed control is off – Bad electrical connections 	<ul style="list-style-type: none"> – Check the circuit breaker – Turn fan speed control on – Check and correct problem
There is power to the fan but it is not operating	<ul style="list-style-type: none"> – Bad electrical connections – The fan speed control's low voltage setting is too low – The fan speed control is bad 	<ul style="list-style-type: none"> – Check and correct problems with connections. Pay special attention to the wiring in the junction box – Increase the setting with the plastic screw on the fan speed control's front plate – Replace the fan speed control
There is power to the fan but it hums and does not turn	<ul style="list-style-type: none"> – The motor run capacitor may be bad. – Creosote may stick 	<ul style="list-style-type: none"> – Check capacitor and replace if necessary – Clean fan
The fan seems to work fine, but there is not enough draft	<ul style="list-style-type: none"> – The fan may be undersized 	<ul style="list-style-type: none"> – Replace with a larger fan
The fan vibrates	<ul style="list-style-type: none"> – The motor shaft may be bent 	<ul style="list-style-type: none"> – Replace motor
There is airflow noise from the fireplace opening	<ul style="list-style-type: none"> – The flue is undersized. – The fan is oversized and running too fast 	<ul style="list-style-type: none"> – There is not much to do about it. Try to reduce the fireplace opening – Reduce the fan speed
Mechanical noise can be heard	<ul style="list-style-type: none"> – Foreign matter may be stuck – Motor bearings may be worn out 	<ul style="list-style-type: none"> – Remove matters – Replace bearings

3000270 08.17